

TM-U925

User's Manual

Printer parts

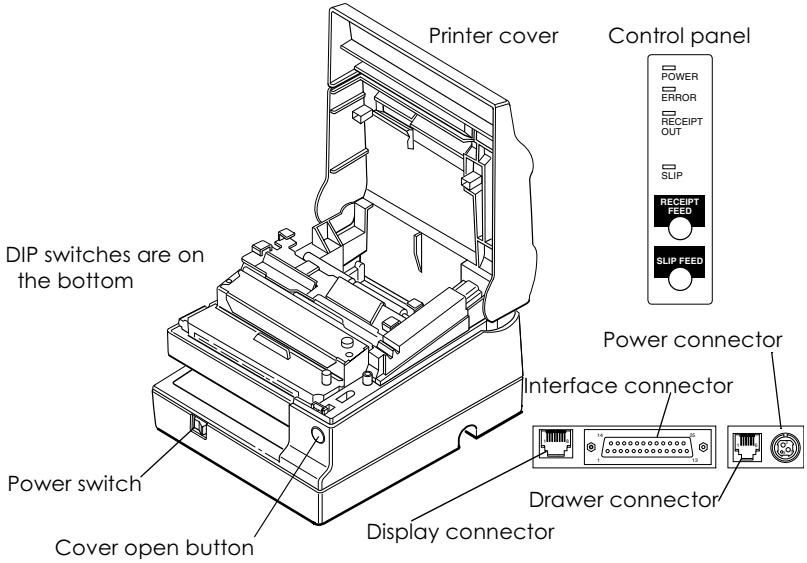

Control panel

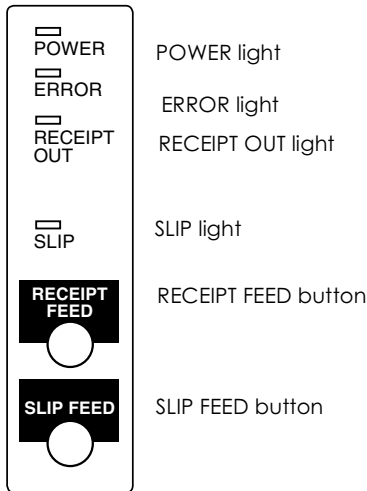

All rights reserved. No part of this publication may be reproduced, stored in a retrieval system, or transmitted in any form or by any means, mechanical, photocopying, recording, or otherwise, without the prior written permission of Seiko Epson Corporation. No patent liability is assumed with respect to the use of the information contained herein. While every precaution has been taken in the preparation of this book, Seiko Epson Corporation assumes no responsibility for errors or omissions. Neither is any liability assumed for damages resulting from the use of the information contained herein.

Neither Seiko Epson Corporation nor its affiliates shall be liable to the purchaser of this product or third parties for damages, losses, costs, or expenses incurred by purchaser or third parties as a result of: accident, misuse, or abuse of this product or unauthorized modifications, repairs, or alterations to this product, or (excluding the U.S.) failure to strictly comply with Seiko Epson Corporation's operating and maintenance instructions.

Seiko Epson Corporation shall not be liable against any damages or problems arising from the use of any options or any consumable products other than those designated as Original Epson Products or Epson Approved Products by Seiko Epson Corporation.

EPSON and ESC/POS are registered trademarks of Seiko Epson Corporation.

NOTICE: The contents of this manual are subject to change without notice.

Copyright © 1995, 1998 by Seiko Epson Corporation, Nagano, Japan.

EMC and Safety Standards Applied

Product Name: TM-U925

Model Name: M62UA

The following standards are applied only to the printers that are so labeled. (EMC is tested using the EPSON power supply.)

Europe: CE Marking
Safety: EN60950

North America: EMI: FCC/ICES-003 Class A
Safety: UL 1950/CSA C22.2 No. 950

Japan: EMI: VCCI Class A

Oceania: EMC: AS/NZS 3548

WARNING

The connection of a non-shielded printer interface cable to this printer will invalidate the EMC standards of this device.

You are cautioned that changes or modifications not expressly approved by SEIKO EPSON Corporation could void your authority to operate the equipment.

CE Marking

The printer conforms to the following Directives and Norms

Directive 89/336/EEC	EN 55022 Class B EN 55024 IEC 61000-4-2 IEC 61000-4-3 IEC 61000-4-4 IEC 61000-4-5 IEC 61000-4-6 IEC 61000-4-8 IEC 61000-4-11
----------------------	--

Directive 90/384/EEC EN45501

FCC Compliance Statement

For American Users

This equipment has been tested and found to comply with the limits for a Class A digital device, pursuant to Part 15 of the FCC Rules. These limits are designed to provide reasonable protection against harmful interference when the equipment is operated in a commercial environment.

This equipment generates, uses, and can radiate radio frequency energy and, if not installed and used in accordance with the instruction manual, may cause harmful interference to radio communications. Operation of this equipment in a residential area is likely to cause harmful interference, in which case the user will be required to correct the interference at his own expense.

FOR CANADIAN USERS

This Class A digital apparatus complies with Canadian ICES-003.

Cet appareil numérique de la classe A est conforme à la norme NMB-003 du Canada.

GERÄUSCHPEGEL

Gemäß der Dritten Verordnung zum Gerätesicherheitsgesetz (Maschinenlärminformations- Verordnung-3. GSGV) ist der arbeitsplatzbezogene Geräusch-Emissionswert kleiner als 70 dB(A) (basierend auf ISO 7779).

Introduction

Features

The TM-U925 is a high-quality POS printer that can print on both slip and roll paper. The printer has the following features:

- ❑ Wide slip paper capability (maximum characters per line: 88 with 7 x 9 font).
- ❑ Interface connector within the printer's external dimensions.
- ❑ High throughput using bidirectional, minimum distance printing.
- ❑ Precision paper feeding at 0.176mm {1/144 inch}.
- ❑ Selectable receive buffer size (32 bytes or 2K bytes).
- ❑ Slip ejection.
- ❑ Command protocol based on the ECS/POS® standard.
- ❑ ASB (Automatic Status Back) function that automatically transmits changes in printer status.
- ❑ EPSON® intelligent module connection.
- ❑ EPSON customer display series connection.
- ❑ Optional Magnetic Ink Character Recognition (MICR) reader that enables the printer to perform reading and processing of MICR characters in addition to printing endorsements.

Options and Accessories

- ❑ Magnetic Ink Character Recognition (MICR) reader (factory installed option)
- ❑ Direct connection customer displays, DM-D102 and DM-D203
- ❑ EPSON power supply unit, PS-170 (not required when the TM-U925 is connected to an intelligent module)
- ❑ EPSON ribbon cassette, ERC-31 (P)

About This Manual

Setting Up and Using

- ❑ **Chapter 1** contains information on unpacking the printer, setting it up, running the self test, setting the DIP switches, and adjusting the paper near end detector.
- ❑ **Chapter 2** contains information on using the printer, including the optional MICR reader.
- ❑ **Chapter 3** contains troubleshooting information, including how to clean the optional MICR reader.

Reference

- ❑ **Chapter 4** contains specifications.
- ❑ **Chapter 5** describes all of the printer's commands.

Notes, Cautions, and Warnings



Note:

Notes have important information and useful tips on the operation of your printer.



CAUTION:

Cautions must be observed to avoid minor injury to yourself or damage to your equipment.



WARNING:

Warnings must be followed carefully to avoid serious bodily injury.

Contents

Chapter 1 **Setting Up the Printer**

Opening and Closing the Printer Cover	1-1
Unpacking	1-2
Removing the protective material	1-2
Connecting the Printer to Your Computer	1-3
Connecting the Printer to the Drawer Connector	1-4
Connecting to a Direct Connection Display Module	1-5
Connecting the Power Supply	1-6
Grounding the Printer	1-7
Installing the Ribbon Cassette	1-8
Installing the Paper Roll	1-9
Self Test	1-11
Running the self test with roll paper	1-11
Running the self test with slip paper	1-12
Setting the DIP Switches	1-13
DIP switch functions	1-13
Changing the DIP switch settings	1-14
Adjusting the Paper Near End Detector	1-16

Chapter 2 **Using the Printer**

Operating the Control Panel	2-1
Buttons	2-1
Indicator lights	2-2
Slip Paper Handling	2-3
Using the Power Switch Cover	2-5
Using the MICR Reader (Option)	2-5
Reading MICR characters on personal checks	2-5

Chapter 3 **Troubleshooting**

Troubleshooting	3-1
General problems	3-1
Printing problems	3-1
Paper handling problems	3-3
Cleaning the MICR Mechanism	3-7
Hexadecimal Dump	3-8

Chapter 4 **Reference Information**

Printing Specifications 4-1
Character Specifications 4-2
Ribbon Specifications 4-3
MICR Specifications (Option) 4-3
 MICR use 4-4
 Notes on MICR use 4-5
Paper Specifications 4-5
Electrical Characteristics 4-10
Reliability 4-12
Environmental Conditions 4-12
Character Code Tables 4-13

Chapter 5 **Commands**

Command Notation 5-1
Control Commands 5-2
Additional Commands for the Optional MICR Reader 5-40
Ignored Commands 5-50

Setting Up the Printer

Opening and Closing the Printer Cover

Use these instructions whenever you need to open or close the printer.

Open the printer by pushing the cover-open button and then lifting the printer cover.

Close the printer by pressing on the indentation on the right side of the printer cover until it audibly clicks into place.

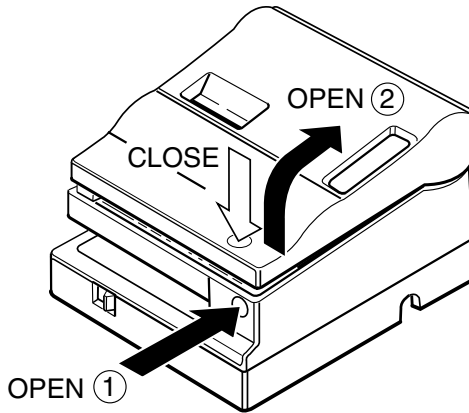

Unpacking

The illustration below shows the items included for the standard specification printer.

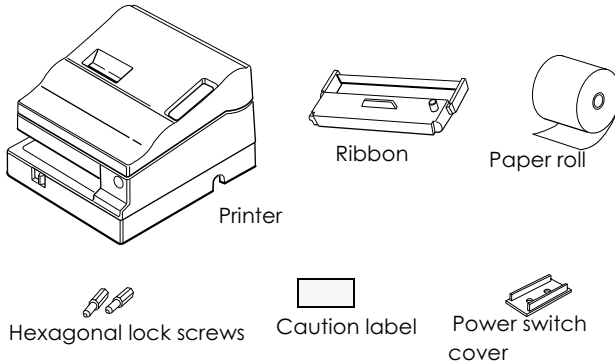

See the note on page 1-3 for information about the hexagonal lock screws.

See the power switch cover section in Chapter 2 for information about the cover.

See the slip paper handling section in Chapter 2 for information about the label.

Removing the protective material

The printer is protected during shipping by a piece of protective material that must be removed before you turn on the printer.

Pull out the protective material and remove it from the printer as shown below.

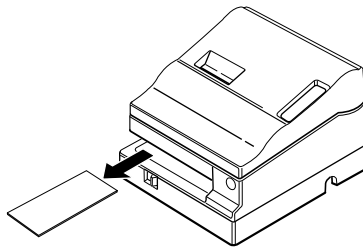

Store the protective material with the other packing materials and use it when transporting your printer.

Connecting the Printer to Your Computer

Follow the procedures below only when you use the printer as a single unit (not connected to an intelligent module). When you use the printer with the intelligent module, see the *IM-403/405 User's Guide* for details.

You need an appropriate interface cable to connect your computer to the printer's built-in interface.

1. Make sure that both the printer and computer are turned off; then attach the cable connector securely into the printer's interface connector.
2. Tighten the screws on both sides of the cable connector.

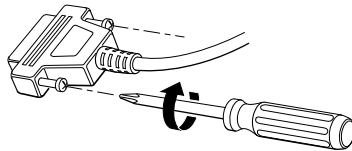

Note:

Your printer comes with inch-type hexagonal lock screws installed. To use an interface cable that requires millimeter-type screws, replace the inch-type screws with the enclosed millimeter-type screws using a hex screwdriver (5 mm). To distinguish the two types of screws, see the figure below. The inch-type screw is on the left.

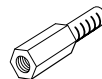
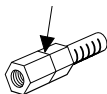

3. Attach the other end of the cable into the computer.
4. Plug the power supply's power cord into an electrical outlet.

Connecting the Printer to the Drawer Connector

Follow the procedures below to connect a drawer to the printer only when you use the printer as a single unit (not connected to an intelligent module). When you use the printer with the intelligent module, see the *IM-403/405 User's Guide* for details.

You need an appropriate drawer kick-out cable to connect your drawer to the printer. See Chapter 4 for more information about the drawer interface.

1. Make sure that the printer is turned off.
2. Plug the cable connector into the printer's drawer kick-out connector until it clicks.

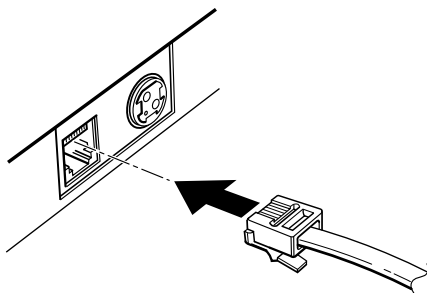

⚠ CAUTION:

Be sure not to connect this cable to the display module connector, which is on the other side of the interface connector.

Do not connect a telephone line to the drawer kick-out connector.



Note:

To remove the cable connector, squeeze the connector's clip and pull it out.

Connecting to a Direct Connection Display Module

If you are using the printer as a single unit (not connected to an intelligent module) and you plan to connect a direct connection display module, follow the steps below. When you use the printer with the intelligent module, see the *IM-403/405 User's Guide* for details.

1. Make sure that the printer is turned off.
2. Plug the cable connector (provided with the direct connection display module) securely into the printer's display module connector until it clicks.

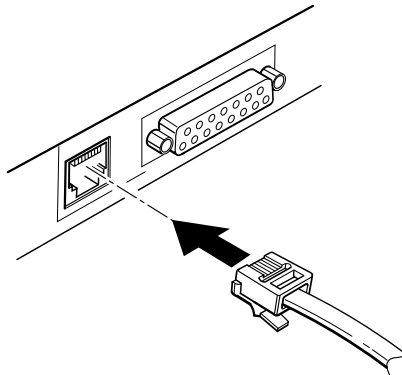

CAUTION:

Do not connect this cable to the drawer kick out connector, which is on the other side of the interface connector. Also do not connect a telephone line to the display module connector.

**Note:**

To remove the cable, squeeze the connector and pull it out.

Connecting the Power Supply

When the printer is used as a single unit, not connected to an intelligent module, use the optional EPSON PS-170 power supply for your printer.

When the printer is connected to an intelligent module, the power is supplied by the intelligent module. See the *IM-403/405 User's Guide* for details.



CAUTION:

Make sure that you use the EPSON PS-170 power supply. When connecting or disconnecting the power supply from the printer, make sure that the power supply is not plugged into an electrical outlet.

1. Make sure that the printer's power switch is turned off, and the power supply's power cord is unplugged from the electrical outlet.
2. Check the label on the power supply to make sure that the voltage required by the power supply matches that of your electrical outlet.



CAUTION:

If the power supply's rated voltage and your outlet's voltage do not match, contact your dealer for assistance. Do not plug in the power cord.

3. Plug in the power supply's cable as shown below. Notice that the flat side of the plug faces down.

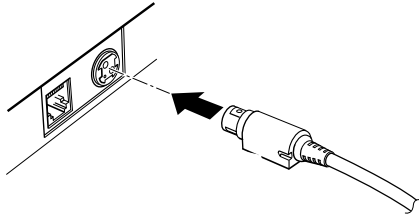

Note:

To remove the DC cable connector, make sure that the power supply's power cord is unplugged; then grasp the connector at the arrow and pull it straight out.

Grounding the Printer

When you use the printer as a single unit (not connected to an intelligent module), you need an appropriate ground wire to ground your printer.

1. Make sure that the printer is turned off.
2. Connect the ground wire to the printer using the FG screw on the bottom of the printer, as shown.

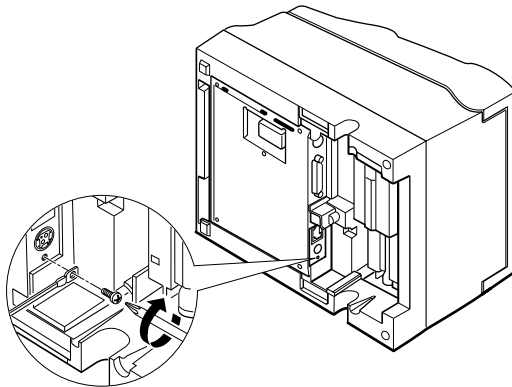

Installing the Ribbon Cassette

Use Epson ERC-31 (P) ribbon cassette for your printer.

CAUTION:

Never turn the ribbon cassette's feed knob in the opposite direction of the arrow marked on the cassette.

1. Turn on the printer and open the printer cover.
2. Turn the ribbon cassette's knob two or three times in the direction of the arrow to take up any slack in the ribbon.

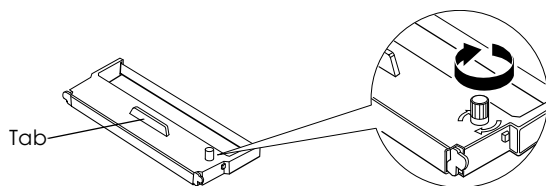

3. Insert the ribbon cassette in the printer and rotate the cassette's knob two or three more times as shown below. This is necessary to place the ribbon in the correct position.

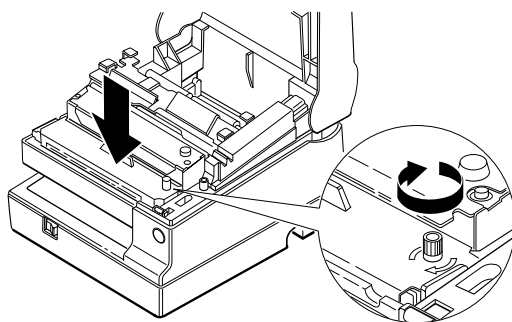

Make sure that the ribbon is installed in front of the print head without wrinkles or creases. If it is hard to see, open the print head cover as described in Chapter 3.

If the ribbon is not installed correctly, remove the cassette as described below and repeat steps 2 and 3 above.



Note:

To remove the ribbon cassette, grasp the ribbon cassette's tab and pull it out of the printer. See the illustration in step 2 above for the location of the tab.

Installing the Paper Roll

Use a paper roll that matches the printer's specifications. See Chapter 4 for paper specifications.

1. Make sure that the edge of the paper is straight, as shown on the left side of the illustration.

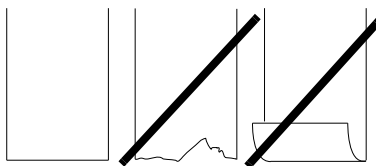

2. Turn on the printer and open the printer cover.

3. Insert a paper roll, as shown below.

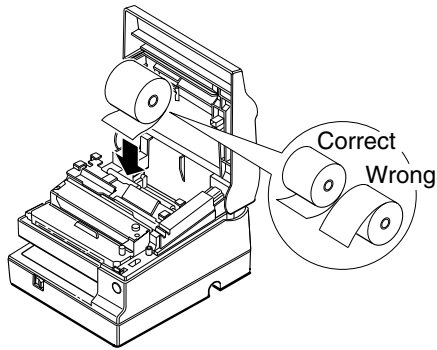

4. Insert the tip of the paper into the paper inlet and push it in until it is automatically detected and fed into the printer.

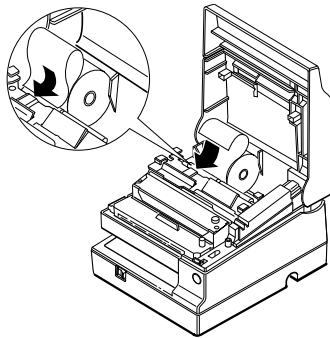

5. Tear off the paper on the cutter. If the paper was not fed far enough, press the RECEIPT FEED button to feed additional paper.



Note:

To remove the paper roll, hold down the paper release lever (marked PRESS) and pull out the paper roll in the direction shown in the illustration.

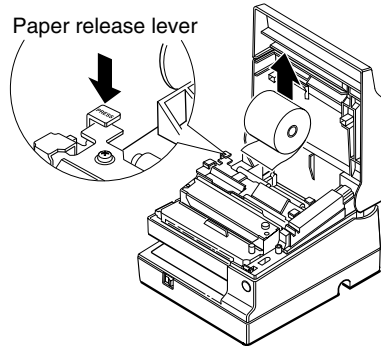

Self Test

The self test lets you know if your printer is operating properly. You can run the self test with either roll paper or slip paper.

Running the self test with roll paper

1. Make sure the printer is turned off and the printer cover is closed properly.
2. While holding down the RECEIPT FEED button, turn on the printer to begin the self test. The self test prints the printer settings and then pauses. (The RECEIPT OUT light blinks.)
3. Press the RECEIPT FEED button to continue printing. The printer prints a pattern using the built-in character set.
4. The self test automatically ends after printing the following:

*** completed ***

The printer is ready to receive data as soon as it completes the self test.



Note:

If you want to pause the self test manually, press the RECEIPT FEED button. Then press the RECEIPT FEED button to continue the self test.

Running the self test with slip paper



Note:

Be sure to install the paper roll to prevent slip paper jams.

1. Make sure the printer is turned off and the printer cover is closed properly.
2. While holding down the SLIP FEED button, turn on the printer to begin the self test. (The SLIP light blinks.)
3. Feed a sheet of slip paper into the printer. The printer loads the paper automatically, prints the printer settings, and then ejects the paper. (The SLIP light blinks.)
4. Remove the paper from the printer and feed another sheet of slip paper into the printer to print characters from the character table. Continue to feed slip paper into the printer until the self test prints the following:

completed

The printer is ready to receive data as soon as it completes the self test.



Note:

If you want to pause the self test manually, press the SLIP FEED button. Press the SLIP FEED button to continue the self test.

Setting the DIP Switches

DIP switch functions

Your printer has two sets of DIP switches. The functions of the switches are shown in the tables below.

Set 1

SW	Function	ON	OFF	Factory settings
1-1	Data word length	7 bits	8 bits	OFF
1-2	Parity	Enabled	Disabled	OFF
1-3	Parity selection	Even	Odd	OFF
1-4	Transmission speed selection (See the table below)			OFF
1-5				OFF
1-6	Customer display connection*	Connected	Not connected	OFF
1-7	Data receive error	Ignored	Prints ?	OFF
1-8	Handshaking	XON/XOFF	DTR/DSR	OFF

* Effective when a direct connection display module is connected to the printer's display module connector.

Transmission Speed

Transmission Speed (BPS)	1-4	1-5
1200	ON	ON
2400	OFF	ON
4800	ON	OFF
9600	OFF	OFF

Set 2

SW	Function	ON	OFF	Factory settings
2-1	Auto line feed	Always enabled	Always disabled	OFF
2-2	Receive buffer	32 bytes	2048 bytes	OFF
2-3	Font selection (default)	9 x 9	7 x 9	OFF
2-4	Carriage speed (default for paper roll printing)	Low	High	OFF
2-5	Handshaking (BUSY condition)	Receive buffer-full	Off-line or receive buffer-full	OFF
2-6	Internal use	Fixed	-	ON
2-7	I/F pin 6 reset signal	Enabled	Disabled	OFF
2-8	I/F pin 25 reset signal	Enabled	Disabled	OFF

Notes:

1. When pin 6 of the interface connector is used for the reset signal, the printer is reset at MARK on the RS-232C level.
2. When pin 25 of the interface connector is used for the reset signal, the printer is reset at SPACE on the RS-232C level or at HIGH on the TTL level.
3. DIP switches excluding switch 2-1 (Auto line feed) and switches 2-7 and 2-8 (interface reset signal) are effective only while the printer power is turned on. If the DIP switch setting is changed after the printer power is turned on, the change is not effective.
4. If DIP switch 2-7 or 2-8 is on while the printer power is turned on, the printer may be reset, depending on the signal state. DIP switches should not be operated while the printer power is turned on.

Changing the DIP switch settings

If you need to change settings, follow the steps below to make your changes:

CAUTION:

Turn off the printer while removing the DIP switch cover to prevent an electric short, which can damage the printer.

1. Make sure the printer is turned off.
2. Remove the screw from the DIP switch cover. Then take off the DIP switch cover, as shown in the illustration below.

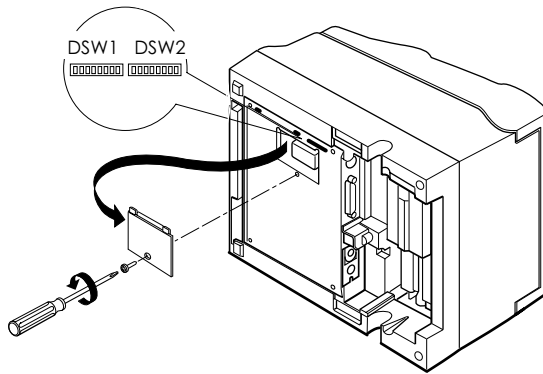

3. Set the switches using a pointed tool, such as tweezers or a small screwdriver.

4. Replace the DIP switch cover by inserting it upward and sliding it to the left as shown below. Then secure it with the screw.

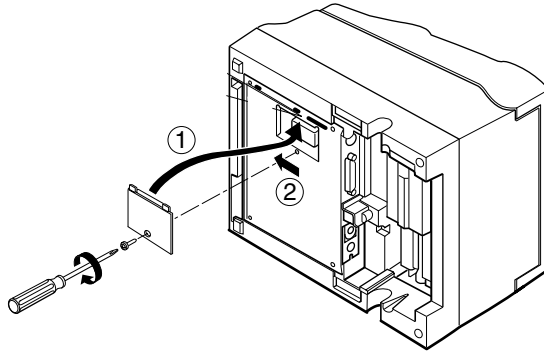

5. The new settings take effect when you turn on the printer.

Adjusting the Paper Near End Detector

The paper near end detector detects when the paper is almost gone by measuring the diameter of the paper roll. Software programs can use the **ESC c 4** command to stop printing when the paper is almost gone.

If you want to change the amount of paper remaining when the printer stops printing, follow the steps below to adjust the paper near end detector.



Note:

The printer also has a paper end-sensor that stops the printer at the very end of a roll. This sensor cannot be turned off by software.

1. Open the printer cover and remove the paper roll.

- Determine the point on the paper roll at which you want the paper roll end detection to be triggered. Then measure the distance A shown in the illustration.

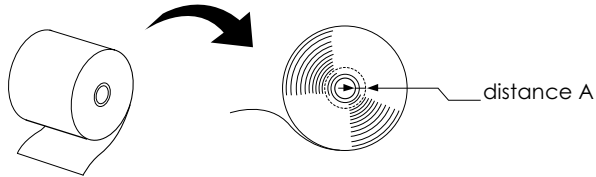

Note:

There may be some difference between the measured distance A and the actual sensing position.

- Find the corresponding adjustment position number from the table below.

Distance A	Adjustment position number
10 mm (0.39 inch)	#1
8 mm (0.32 inch)	#2
6 mm (0.24 inch)	#3
4 mm (0.16 inch)	#4
2 mm (0.08 inch)	#5

4. Locate the adjusting screw and the positioning plate shown in the illustration below.

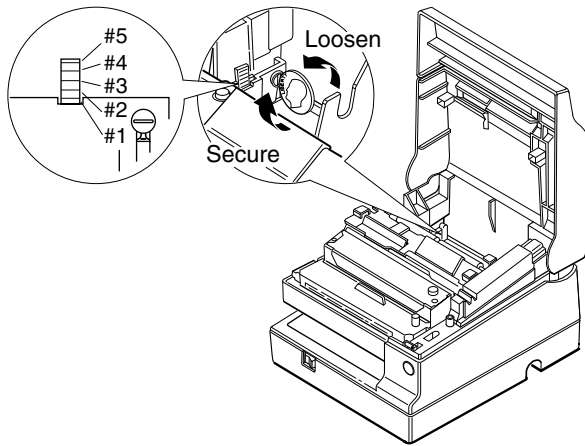

5. Loosen the adjusting screw with a coin or a screwdriver. Move the positioning plate to the appropriate position and then tighten the adjusting screw, as shown below. Position 1 leaves the least paper on the roll, and position 5 leaves the most
6. Be sure that the detecting lever moves freely after you finish the adjustment.
7. Re-install the paper roll, as described earlier in this chapter.

Chapter 2

Using the Printer

Operating the Control Panel

You can control the basic paper feeding operations of the printer with the buttons on the control panel. The indicator lights help you monitor the printer's status.

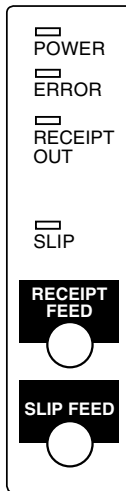

Buttons

These buttons can be disabled by the **ESC c 5** command, but they work whenever the printer cover is open, even if they have been disabled by the **ESC c 5** command.

RECEIPT FEED

Press the RECEIPT FEED button once to advance receipt paper one line. You can also hold down RECEIPT FEED to feed receipt paper continuously.

SLIP FEED

You cannot load slip paper using this button. Slip paper can be loaded only by selecting slip paper with a command and then inserting the paper. When the printer is in the slip paper mode (the SLIP light is on or blinking) and slip paper is inserted, you can press the SLIP FEED button once to advance slip paper one line or hold down SLIP FEED to feed slip paper continuously.

Indicator lights

The control panel lights provide information on printer conditions.

POWER (green)

The POWER light is on when the printer power is on.

ERROR (red)

The ERROR light is on or blinking when the printer is not ready to print.

The ERROR light is on (not blinking) under the following conditions:

- When the printer is first turned on or reset through the interface. The light goes off as soon as the printer is initialized.
- When the printer cover is open.
- When the printer is at or near the end of a roll of paper.

The ERROR light blinks under the following conditions:

- When the print head is overheated. If this happens, the printer waits until the print head cools and then resumes printing.
- When an error occurs.

For more information on error conditions, see Chapter 4, "Troubleshooting."

RECEIPT OUT (red)

The RECEIPT OUT light is on (not blinking) when the paper roll is not installed or is at or near the end. The RECEIPT OUT light blinks after the self test prints the printer settings on the roll paper.

SLIP (green)

The SLIP light is on or blinking while the printer is in slip paper mode.

The SLIP light blinks while the printer is waiting for slip paper to be inserted or removed.

Slip Paper Handling

Use only slip paper that matches the printer's specifications. See Paper Specifications in Chapter 4.



Note:

Be sure to install a paper roll in the printer even if you plan to print only on slip paper. This will prevent paper jams. You can also prevent paper jams by using slip paper that is flat and has no wrinkles, creases, or folds.

1. Send appropriate control commands from the computer to print on slip paper.
2. When the SLIP light blinks, insert the slip paper into the slip paper inlet using the right edge of the slip paper inlet as a guide.

Make sure you insert the slip paper into the inlet as far as it will go (i.e., insert the slip paper up to the mark on the left side of the printer).

The paper is automatically drawn into the printer and printing begins.



Note:

Place the caution label, which reminds you how to insert slip paper, on the printer as shown in the illustration below, if necessary.

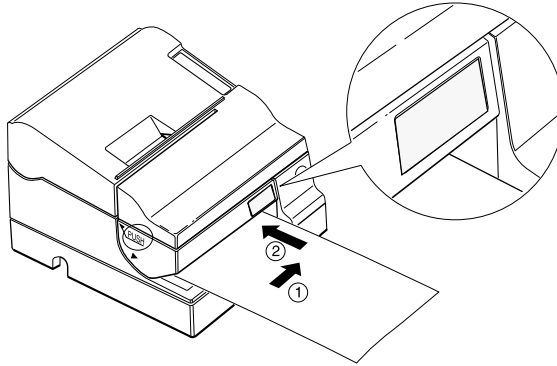

CAUTION:

Be sure to put the caution label exactly in the position shown. If you put it another place, such as over the slip paper inlet, the printer may be damaged.

Using the Power Switch Cover

You can use the enclosed power switch cover to make sure that the power switch is not accidentally pressed. If you want to use this cover, install it as shown in the illustration below.

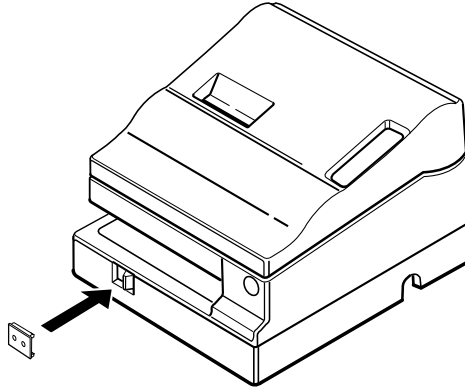

Using the MICR Reader (Option)

If your printer has the factory installed optional Magnetic Ink Character Recognition (MICR) reader that enables the printer to read and process MICR characters on personal checks, read this section.



CAUTION:

Be sure the paper roll is installed before you use the MICR function. Even when you are not using roll paper, this prevents paper jams.

Reading MICR characters on personal checks

To use the MICR function with personal checks, follow the steps below:

CAUTION:

Do not insert checks with staples in them. This may cause paper jams, MICR reading errors, and damage to the MICR head.

Be sure that the checks are flat, without curls, folds, or wrinkles.

1. Wait until the computer sends the **FS a 0** command to the printer, causing it to enter the MICR mode. The SLIP light blinks.
2. Turn the check over so that it is *face down* with the MICR characters on the righthand side, as shown in the illustration below. The MICR characters must be next to the right edge of the paper inlet.

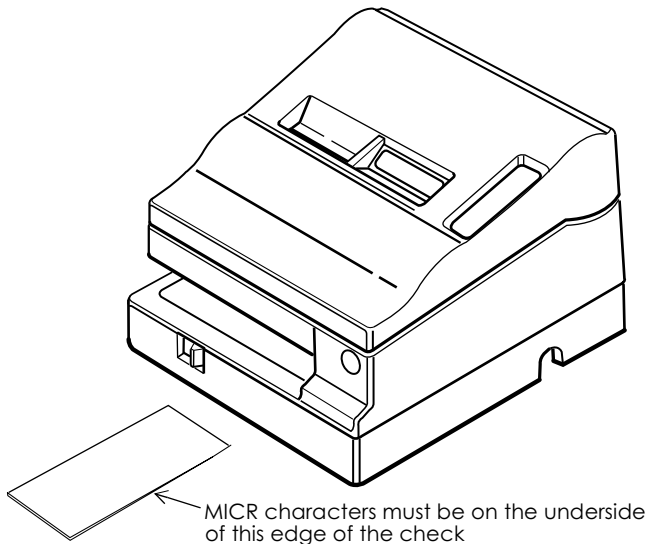

3. Insert the check straight into the paper inlet, using the right edge of the paper inlet as a guide.

4. Insert the check as far as it will go. The printer will detect the check and start drawing it in.
5. When the printer starts drawing it in, let go of the check immediately. The SLIP light quits blinking but stays on.
6. When printing and MICR reading are finished, the printer ejects the check and the SLIP light starts blinking again.
7. Remove the check by pulling it straight up; do not pull it at an angle. The SLIP light goes off.

See Chapter 3 to find out how to clean the MICR mechanism, and see Chapter 4 for further details on using the MICR reader.

Chapter 3

Troubleshooting

Troubleshooting

This chapter gives solutions to some of the more common printer problems.

General problems

The lights on the control panel do not come on.

Make sure that the power supply cables are correctly plugged into the printer, the power unit, and to the power outlet.

Make sure that power is supplied to the power outlet. If the outlet is controlled by a switch or timer, use another outlet.

Printing problems

The **ERROR** light is on (not blinking) and nothing is printed.

If the RECEIPT OUT light is **on**, the paper roll is not installed or is at or near the end. Install a new paper roll in the printer. See Chapter 1 for instructions.

If the RECEIPT OUT light is **off**, make sure that the printer cover is properly closed. Press the round indentation on the printer cover until the cover audibly clicks into place. You may not be able to close the printer cover if one or both of the OPEN <-> LOCK levers is open. See the illustration on page 3-7 to help you close the levers.

The ERROR light is blinking and the printer does not print.

First, turn off the printer and check for a paper jam. (See the paper jam description on page 3-3.)

If there is no paper jam and the printer has been printing for quite a while, the print head may be overheated. If the print head is overheated, the printer will resume printing when the head has cooled (usually within two or three minutes).

If there is no paper jam and the print head is not overheated, turn off the printer and turn it back on after about 10 seconds. If the ERROR light is still flashing, contact a qualified service person.

The ERROR light is off, but nothing is printed.

Try to run the self test to check that the printer works properly. See the self test instructions in Chapter 1 to run the self test. If the self test does not work, contact your dealer or a qualified service person.

If the self test works properly, check the following:

1. Check the connection at both ends of the interface cable between the printer and the computer. Also make sure that this cable meets the specifications for both the printer and the computer.
2. The data transmission settings may be different between the printer and computer. Make sure that the printer's DIP switch settings for data transmission are the same as the computer's. You can print the printer's interface settings using the self test.

If the printer still does not print, contact your dealer or a qualified service person.

The printer sounds like it is printing, but nothing is printed.

The ribbon cassette may not be installed properly. See the instructions in Chapter 1.

The ribbon may be worn out. Replace the ribbon cassette as described in Chapter 1.

The printout is faint.

The ribbon may be worn out. Replace the ribbon cassette as described in Chapter 1.

A line of dots is missing in the printout.

The print head may be damaged. Stop printing and contact your dealer or a qualified service person.

Paper handling problems

Slip paper or personal checks are not fed properly or become jammed frequently.

The paper roll is not installed properly. Remove and reinstall the paper roll as described in Chapter 1.

Paper is jammed inside the printer.

To clear a paper jam, follow the steps below:

1. Turn the printer off and open the printer cover.

2. Cut the paper as shown in the illustration, using a pair of scissors or a knife; then remove the paper roll.

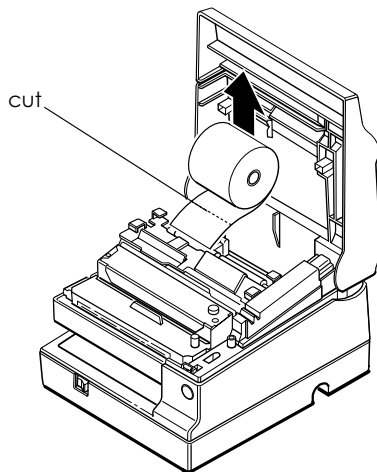

3. If the paper is caught in the automatic cutter blade, open the cutter blade by rotating the gear in the direction shown in the illustration.

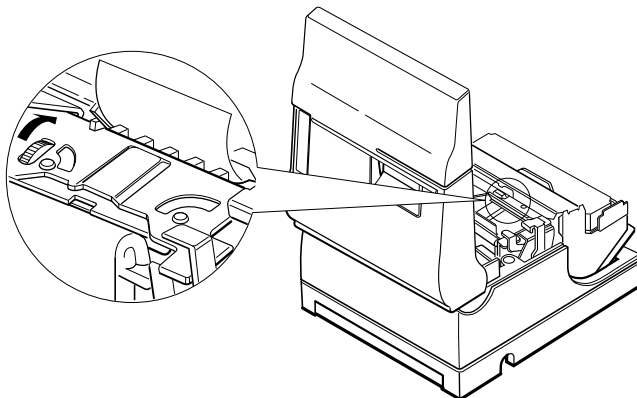

4. Move the OPEN <-> LOCK lever on each side of the printer in the direction shown in the illustration; the cutter unit then opens automatically.

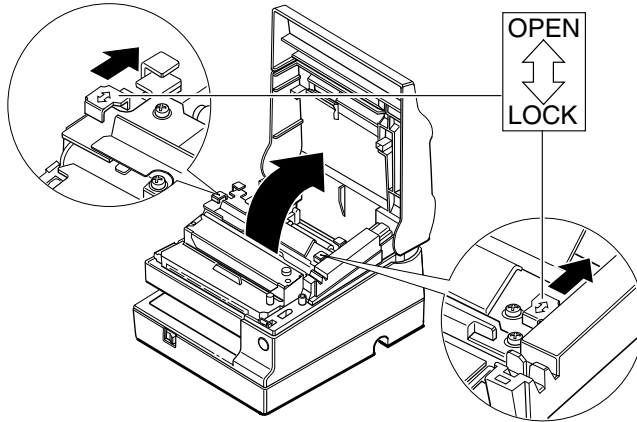

5. Pull the paper out gently. If the paper tears, make sure you remove any remaining pieces.
6. If you encounter difficulty in clearing a paper jam, remove the print head cover by loosening the screw on the right side of the cover, as shown in the illustration below.

  **CAUTION:**

Do not touch the print head because it can be very hot after printing continuously for a long time.

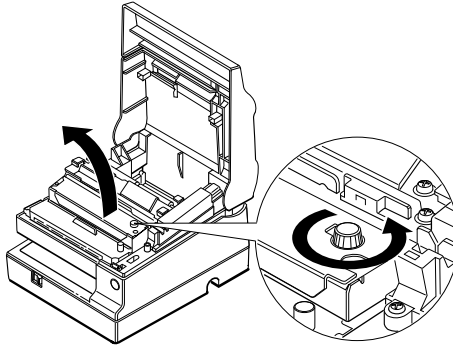

7. Remove any paper from inside the printer.
8. If you removed the print head cover, replace the cover and secure the screw, as shown in the illustration below.

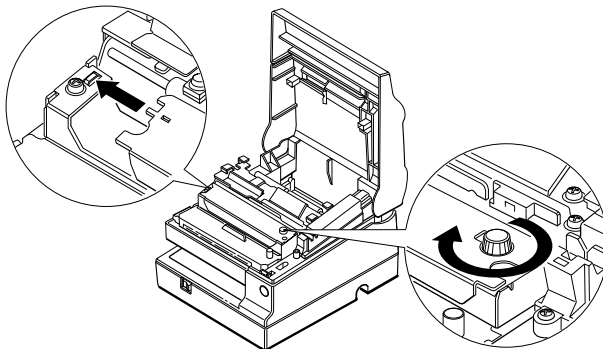

9. Close the cutter unit and lock it by moving both OPEN <-> LOCK levers in the direction shown in the illustration.

CAUTION:

Make sure you lock the cutter unit with both OPEN <-> LOCK levers.

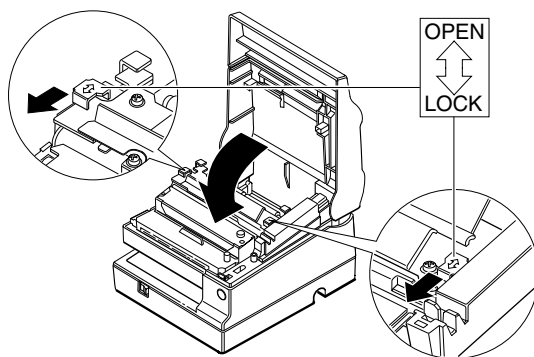

10. Install the paper roll following the steps in Chapter 1; then close the printer cover.

Cleaning the MICR Mechanism

Foreign matter on any part of the MICR mechanism can cause MICR reading errors.

Cleaning the MICR mechanism is simple. First, send the cleaning command (FS c) to the printer. Then insert the special MICR cleaning paper the same way you insert a check.

The printer feeds the paper through, cleaning the MICR head, roller, and paper path.

Perform this cleaning once a month or after every 6,000 checks .

Use a special MICR cleaning paper such as the KIC Products PRESAT brand check reader cleaning card or the equivalent. The size should be 63 x 152 mm (2.48 x 5.98"). (USA only)

Hexadecimal Dump

This feature allows experienced users to see exactly what data is coming to the printer. This can be useful in finding software problems. When you turn on the hex dump function, the printer prints all commands and other data in hexadecimal format along with a guide section to help you find specific commands.

To use the hex dump feature, follow these steps:

1. After you make sure that the printer is off, open the cover.
2. Hold down the RECEIPT FEED button while you turn on the printer.
3. Close the cover.
4. Run any software program that sends data to the printer. The printer prints "Hexadecimal Dump" and then all the codes it receives in a two-column format. The first column contains the hexadecimal codes and the second column gives the ASCII characters that correspond to the codes.

```
Hexadecimal Dump
1B 21 00 1B 26 02 40 40 : .!.. & .@ @
1B 25 01 1B 63 34 00 1B : .%..c4..
41 42 43 44 45 46 47 48 : ABCDEFGH
```

- A period (.) is printed for each code that has no ASCII equivalent.
 - Control codes are printed in bold for emphasis.
 - During the hex dump all commands except **DLE EOT** and **DLE ENQ** are disabled.
5. Open the cover to set the printer off line so that it will print the last line.
 6. Close the cover and turn off the printer or reset it to turn off the hex dump mode.

Chapter 4

Reference Information

Printing Specifications

- Printing method:** Serial impact dot matrix
- Head wire configuration:** 9-pin vertical line, 0.353 mm {1/72"} wire pitch
- Head wire diameter:** 0.29 mm {.01"}
- Printing direction:** Bidirectional, minimum distance printing
- Printing speed:** See table on page 4-2.
- Characters per line:** See table on page 4-2.
- Characters per inch:** See table on page 4-2.
- Print modes:** See the print modes table below.

Print modes

Print mode	Printing speed*1	Print head energizing time	Paper roll		Slip paper	
			Default status	Switching*2	Default status	Switching*2
Normal	High	Normal	Depends on DIP SW 2-4	Possible	--	Possible
Low speed	Low	Normal		Possible	--	Possible
Copy	Low	Copy (long)	--	Possible	Selected	Possible

Note:

*1 The printer automatically goes to low speed mode during bit image printing, regardless of the type of selected paper.

*2 Print mode can be changed using the **GS E** command.

Character Specifications

- Number of characters:** Alphanumeric characters: 95
 International characters: 32
 Extended graphics: 128 × 8 pages
 (including space pages)
- Character structure:** 9 × 9 3-dot spacing (in half dot units)
 7 × 9 2-dot spacing (in half dot units)
 Larger spacing can be set by using
 ESC SP.
- Character size:** See the table below.

*Characters per inch, characters per second,
 characters per line, character size*

Character structure * 1	Character spacing (half dots)	CPI * 2	CPS * 3		CPL * 4		Character size (width x height)
			High	Low	Paper roll	Slip paper	
9 × 9	3 dots	12.5	233	200	30	66	1.6 × 3.1 mm {.06" x .12"}
7 × 9	2 dots	16.7	311	267	40	88	1.3 × 3.1 mm {.05" x .12"}

*1 Horizontal dots x vertical dots

*2 CPI: Characters Per Inch (number of characters per 25.4 mm)

*3 CPS: Characters Per Second (number of characters per second)

*4 CPL: Characters Per Line

Ribbon Specifications

Type:	Exclusive cassette ribbon	
Ribbon cassette specifications:	Part number	ERC-31 (P)
	Color	Purple
	Ribbon life	7,000,000 characters

(when one character consists of 18 dots)

MICR Specifications (Option)

The MICR mechanism is a factory-installed option.

Available fonts:	E-13B, CMC7
Recognition rating:	98% or more at 25°C (75°F) Rating = $([\text{total checks} - \text{number misread or not identified}] / \text{total checks}) \times 100$ Check paper tested is EPSON standard check paper. Checks must be flat, without curls, folds, or wrinkles.
Paper type:	Normal check paper with thickness of 0.09 to 0.2mm {0.0035 to 0.0079"} Size: 68 to 102mm × 152 to 210 mm {2.68 to 4.02 × 2.98 to 8.27"} Mass: 70 to 90 Kg.
Ripple voltage:	300 mVpp or less
Current consumption:	Mean approx. 2.3A (Approx. 1.4 sec)

Reliability:

MICR reader mechanism (only when the printer is used with the MICR reader):

MCBF: 160,000 passes

Life: 240,000 passes

(One pass: from reading characters to printing endorsements on a U.S.A. personal check (152 mm {5.98"} long)

(The MICR reader is defined to have reached the end of its life when it cannot function properly because of the main parts (magnetic head, head holding roller, etc.) of wearing out.)

MICR use

Use the following procedure to read MICR characters.

	User Operation	Printer Operation
1	Transmits FS a 0 <00>H.	Mechanically switches to MICR mode and waits for a personal check to be loaded. The SLIP light blinks.
	(Transmits DLE ENQ 3.)	(when the check waiting state is canceled)
2	Inserts a check.	Detects the check, lights the SLIP light, and reads MICR characters. After reading, transmits the reading results.
3	(Transmits FS a 0 <00>H.)	(Re-reads the check and transmits the reading result.)
4	Transmits FS a 1.	Loads the check paper to the print starting position.
5	Transmits endorsement printing data.	Prints data and feeds paper.
6	Transmits FF.	After printing, ejects paper. The SLIP light blinks until the check is removed.
7	Removes the check paper.	The SLIP light blinks.

Notes on MICR use

- ❑ Personal checks are fed in the forward direction only.
- ❑ The paper roll must be loaded correctly before selecting MICR function. Otherwise, check paper is not fed properly.
- ❑ The check waiting state is canceled using **DLE ENQ 3**.
- ❑ After a personal check is ejected, the SLIP light comes on and the printer does not proceed to the next operation until the check is removed.
- ❑ The check waiting time and the interval from when a check is inserted to when the operation starts can be set using **ESC f**.
- ❑ To check the MICR function status exactly, use **DLE EOT BS 1**.
- ❑ Remove ejected personal checks by pulling them upward. Do not pull them out in the horizontal direction.

Paper Specifications

Paper feed method:	Friction feed
Paper feed pitch:	Default 4.23 mm {1/6 inch} Can be set in units of 0.353 mm {1/144 inch} by the ESC 3 and ESC J commands.
Paper feed speed:	Approx. 60.3 ms/line (4.23 mm {1/6 inch} feeding) Approx. 86.36 mm/second {3.4 inches/second} (continuous feeding)
Paper size:	Paper roll (single-ply)

Size: Width 69.5 mm \pm 0.5 mm
{2.74" \pm 0.02"}

Maximum
outside
diameter: 83 mm {3.27"}

Thickness: 0.06 to 0.09 mm {.0024 to
.0035"}

Mass: 52.3 to 64.0 g/m² {13.9 to
17 lbs} (JIS P8124) (45 to
55 Kg {20.41 to 24.94 lbs})/
1000 sheets/788 mm \times
1091mm {31.02" \times 42.95"}

Paper roll
inside
diameter: 10 mm {0.39"} or more

Slip paper

Paper type: Normal paper

Carbon copy paper

Pressure sensitive paper

Total
thickness: 0.09 to 0.36 mm {.0035 to
.0141"}

See the *Copy capability and paper
thickness* portion on the next page for
more information.

Size
(W \times L): 70 mm \times 70 mm to 210
mm \times 297 mm (A4 size)
{2.76" \times 2.76" to 8.27" \times
11.69"}

Ambient temperature and copy capability

Copy capability is greatly influenced by the ambient temperature, so printing must be performed under the conditions described in the table below.

Relationship between ambient temperature and number of copies

Number of copies	Ambient temperature (print mode)
Original + 4 copies	20° to 40°C {68° to 104°F} (copy mode)
Original + 1 to 3 copies	5° to 40°C {41° to 104°F} (copy mode)

Copy capability and paper thickness:

Normal paper (single-ply): 0.09 to 0.2 mm {.0035 to .0079"}

Carbon copy paper combination:
5 sheets maximum
(original + 4 copies, at 20° to 40°C {68° to 104°F})

Backing paper:

0.06 to 0.15 mm {.0023 to .0059"}

Copy and original:

0.04 to 0.07 mm {.0015 to .0028"}

Carbon paper:

Approx. 0.035 mm {.0014"}

Total thickness:	0.30 mm {.0118"} or less (original to original + 3 copies)
	0.36 mm {.014"} or less (original + 4 copies)
Pressure sensitive paper:	5 sheets maximum (original + 4 copies, at 20° to 40°C {68° to 104°F})
Backing paper:	0.06 to 0.15 mm {.0023 to .0059"}
Copy and original:	0.06 to 0.075 mm {.0023 to .003"}
Total thickness:	0.24 mm {.0094"} or less (original to original + 3 copies)
	0.30 mm {.0118"} or less (original + 4 copies)



Note:

When using multi-ply paper that consists of an original and three copies, be sure to print with a 9 × 9 font. If a 7 × 9 font is used, some characters on some of the copies may not be readable.

Notes on slip paper

- ❑ The slip paper must be flat, without curls or wrinkles, especially at the top edges. Otherwise, the paper may rub against the ribbon and become dirty.
- ❑ There must be no glue on the bottom edge of slip paper. It is desirable for the glue to be on the top edge. Choose slip paper carefully when the glue is on the right or left edge, since paper feeding and insertion are affected by gluing conditions (e.g., glue quality, method, and length) and glue location. (See the

illustration below.) Be especially careful when slip paper is wide and has the glue on the right or left edge, since it may not feed in a straight line.

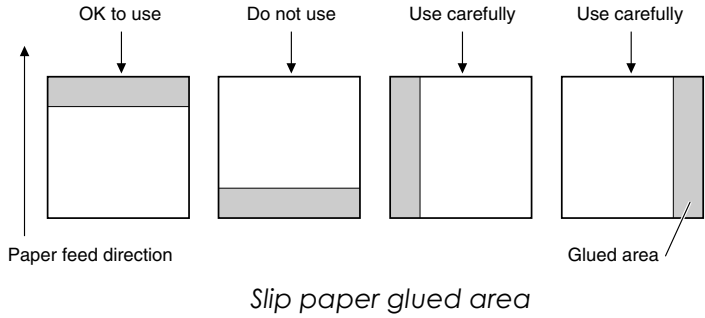

- ❑ Since the slip insertion detector uses a photo detector, paper that has holes at the detector position, or is translucent, must not be used. (See the illustration on the next page.)

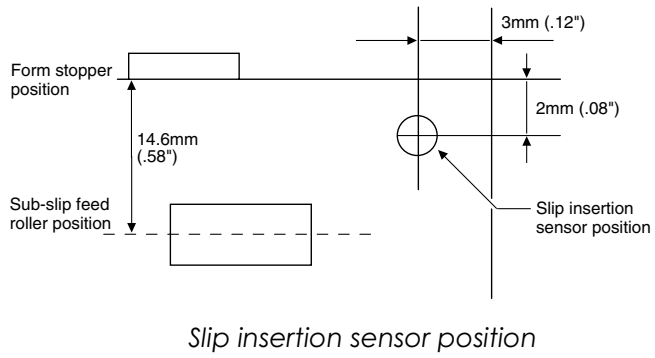

- ❑ Since the slip ejection detector uses a reflective photo detector, paper that has holes or dark portions with low reflection (less than 40% reflection) at the detector position must not be used. (See the illustration below.)

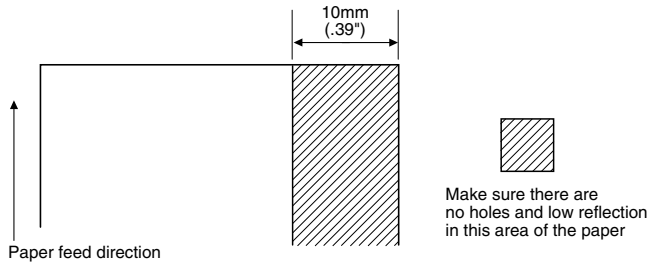

Paper holes and low reflection prohibited area

- ❑ Be sure to perform slip printing with a paper roll loaded to avoid paper jams.
- ❑ Use thinner paper (N30 or equivalent) between the top and bottom sheets of multi-ply paper. If thick paper is used, the copy capability is lowered

Electrical Characteristics

Supply voltage: +24 VDC \pm 10%

Current consumption: Operating:

When feeding slip paper to the print starting position: Mean - approx. 2.3 A, approx. 1.4 seconds

Printing: Mean - approx. 1.8 A
(when printing
alphanumeric
characters for
maximum number
printing on paper roll)
Peak - approx. 8.0 A

Standby: Mean - approx. 0.3 A

Reliability

**Printer mechanism
(MCBF):**

5,000,000 lines

- When performing autocutting and stamping once each for every 15 lines printed.

Life:

7,500,000 lines

- The printer is defined to have reached the end of its life when it cannot function properly because of the main parts (motors, solenoids, frames, shafts, etc.) wearing out.)

Print head life:

150 million characters

- When printing an average of 2 dots/wire per character.

Environmental Conditions

Temperature:

Operating: 5° to 40°C {41° to 104°F}

Storage: -10° to 50°C {14° to 122°F}
(except for ribbon)

Humidity:

Operating: 30 to 80% RH (at 30°C or more, the upper limit condition is 30°C, 80% or equivalent, with no condensation)

Storage: 30 to 90% RH (with no condensation, except for ribbon)

Character Code Tables

The following pages show the character code tables. To find the character corresponding to a hexadecimal number, count across the top of the table for the left digit and count down the left column of the table for the right digit. For example, 4A = J

Page 0 (PC437: U.S.A., Standard Europe) (International character set: U.S.A.)

HEX	0	1	2	3	4	5	6	7	8	9	A	B	C	D	E	F
0 0000	000	001	002	003	004	005	006	007	008	009	010	011	100	101	110	111
0 0010	00A	00B	00C	00D	00E	00F	010	011	012	013	014	015	100	101	110	111
1 0001	010	011	012	013	014	015	016	017	018	019	01A	01B	100	101	110	111
2 0010	020	021	022	023	024	025	026	027	028	029	02A	02B	100	101	110	111
3 0011	030	031	032	033	034	035	036	037	038	039	03A	03B	100	101	110	111
4 0100	040	041	042	043	044	045	046	047	048	049	04A	04B	100	101	110	111
5 0101	050	051	052	053	054	055	056	057	058	059	05A	05B	100	101	110	111
6 0110	060	061	062	063	064	065	066	067	068	069	06A	06B	100	101	110	111
7 0111	070	071	072	073	074	075	076	077	078	079	07A	07B	100	101	110	111
8 1000	080	081	082	083	084	085	086	087	088	089	08A	08B	100	101	110	111
9 1001	090	091	092	093	094	095	096	097	098	099	09A	09B	100	101	110	111
A 1010	0A0	0A1	0A2	0A3	0A4	0A5	0A6	0A7	0A8	0A9	0AA	0AB	100	101	110	111
B 1011	0B0	0B1	0B2	0B3	0B4	0B5	0B6	0B7	0B8	0B9	0BA	0BB	100	101	110	111
C 1100	0C0	0C1	0C2	0C3	0C4	0C5	0C6	0C7	0C8	0C9	0CA	0CB	100	101	110	111
D 1101	0D0	0D1	0D2	0D3	0D4	0D5	0D6	0D7	0D8	0D9	0DA	0DB	100	101	110	111
E 1110	0E0	0E1	0E2	0E3	0E4	0E5	0E6	0E7	0E8	0E9	0EA	0EB	100	101	110	111
F 1111	0F0	0F1	0F2	0F3	0F4	0F5	0F6	0F7	0F8	0F9	0FA	0FB	100	101	110	111



Note: The character code tables show only which characters are printed. They do not show the actual print pattern.

	HEX	8	9	A	B	C	D	E	F
HEX	BIN	1000	1001	1010	1011	1100	1101	1110	1111
0	0000	—	⊥	SP	—	タ	ミ	ニ	×
		128	144	160	176	192	208	224	240
1	0001	—	⌈	。	ア	チ	ム	ト	円
		129	145	161	177	193	209	225	241
2	0010	—	⌋	「	イ	ツ	メ	キ	年
		130	146	162	178	194	210	226	242
3	0011	■	⌌	」	ウ	テ	モ	コ	月
		131	147	163	179	195	211	227	243
4	0100	■	—	、	エ	ト	ヤ	▲	日
		132	148	164	180	196	212	228	244
5	0101	■	—	・	オ	ナ	ユ	▲	時
		133	149	165	181	197	213	229	245
6	0110	■		ヲ	カ	ニ	ヨ	▲	分
		134	150	166	182	198	214	230	246
7	0111	■		ア	キ	ヌ	ラ	▲	秒
		135	151	167	183	199	215	231	247
8	1000		┌	イ	ク	ネ	リ	♠	〒
		136	152	168	184	200	216	232	248
9	1001		┐	ウ	ケ	ノ	ル	♥	市
		137	153	169	185	201	217	233	249
A	1010		└	エ	コ	ハ	レ	♦	区
		138	154	170	186	202	218	234	250
B	1011		┘	オ	サ	ヒ	ロ	♣	町
		139	155	171	187	203	219	235	251
C	1100	■	┌	ヤ	シ	フ	ワ	●	村
		140	156	172	188	204	220	236	252
D	1101	■	┐	ユ	ス	ヘ	ン	○	人
		141	157	173	189	205	221	237	253
E	1110	■	└	ヨ	セ	ホ	・	/	〒
		142	158	174	190	206	222	238	254
F	1111	+	┘	ツ	ソ	マ	・	＼	SP
		143	159	175	191	207	223	239	255

HEX	8	9	A	B	C	D	E	F	
HEX	BIN	1000	1001	1010	1011	1100	1101	1110	1111
0	0000	Ç 128	É 144	Á 160	⌘ 176	Ł 192	Š 208	Ō 224	— 240
1	0001	Û 129	Æ 145	Í 161	⌘ 177	± 193	Đ 209	β 225	± 241
2	0010	É 130	Æ 146	Ó 162	⌘ 178	Ƨ 194	È 210	Ō 226	— 242
3	0011	Â 131	Ô 147	Ú 163	 179	† 195	È 211	Ō 227	š 243
4	0100	Ä 132	Ö 148	Ŧ 164	† 180	— 196	È 212	ö 228	Ŧ 244
5	0101	À 133	Ò 149	Ñ 165	À 181	+ 197	ı 213	Ō 229	š 245
6	0110	Ā 134	Ū 150	Ǽ 166	Ā 182	ā 198	ı̇ 214	μ 230	÷ 246
7	0111	Ç 135	Û 151	Ō 167	Ā 183	Ā 199	ı̇ 215	þ 231	š 247
8	1000	È 136	Ÿ 152	Č 168	© 184	Ł 200	Ÿ 216	þ 232	° 248
9	1001	Ë 137	Ö 153	© 169	† 185	Ƨ 201	Ƨ 217	Ú 233	° 249
A	1010	È 138	Û 154	Ƨ 170	 186	± 202	Ƨ 218	Ū 234	° 250
B	1011	İ 139	ø 155	½ 171	Ƨ 187	Ƨ 203	■ 219	Û 235	ı̇ 251
C	1100	Î 140	Š 156	† 172	Ƨ 188	† 204	■ 220	Ÿ 236	š 252
D	1101	Ì 141	Ø 157	ı̇ 173	Ƨ 189	— 205	ı̇ 221	Ÿ 237	š 253
E	1110	Ä 142	× 158	« 174	Ÿ 190	+ 206	ı̇ 222	■ 238	■ 254
F	1111	Ä 143	f 159	» 175	Ƨ 191	Ƨ 207	■ 223	ı̇ 239	SP 255

HEX	HEX	8	9	A	B	C	D	E	F
HEX	BIN	1000	1001	1010	1011	1100	1101	1110	1111
0	0000	Ç 128	È 144	á 160	⌘ 176	⌚ 192	⌛ 208	α 224	≡ 240
1	0001	ü 129	À 145	í 161	⌘ 177	⌚ 193	⌛ 209	β 225	± 241
2	0010	é 130	Ê 146	ó 162	⌘ 178	⌚ 194	⌛ 210	Γ 226	≥ 242
3	0011	â 131	ô 147	ú 163	⌘ 179	⌚ 195	⌛ 211	π 227	≤ 243
4	0100	ã 132	ø 148	ñ 164	⌘ 180	- 196	⌚ 212	Σ 228	ƒ 244
5	0101	à 133	ò 149	Ñ 165	⌘ 181	+ 197	⌚ 213	σ 229	⌚ 245
6	0110	Á 134	Ú 150	ã 166	⌘ 182	⌚ 198	⌛ 214	μ 230	÷ 246
7	0111	ç 135	ù 151	o 167	⌘ 183	⌚ 199	⌛ 215	τ 231	≈ 247
8	1000	ê 136	î 152	ç 168	⌘ 184	⌚ 200	⌛ 216	φ 232	° 248
9	1001	ê 137	ï 153	ò 169	⌘ 185	⌚ 201	⌛ 217	θ 233	• 249
A	1010	è 138	Û 154	⌘ 170	⌘ 186	⌚ 202	⌛ 218	Ω 234	· 250
B	1011	í 139	φ 155	½ 171	⌘ 187	⌚ 203	■ 219	δ 235	√ 251
C	1100	ó 140	£ 156	¼ 172	⌘ 188	⌚ 204	■ 220	∞ 236	∞ 252
D	1101	ì 141	Ü 157	í 173	⌘ 189	- 205	■ 221	ø 237	² 253
E	1110	Ã 142	ϖ 158	« 174	⌘ 190	⌚ 206	■ 222	ε 238	■ 254
F	1111	Â 143	ó 159	» 175	⌘ 191	⌚ 207	■ 223	∩ 239	SP 255

HEX	BIN	8	9	A	B	C	D	E	F
0	0000	Ç 128	É 144	Ï 160	⌘ 176	⌚ 192	⌛ 208	α 224	≡ 240
1	0001	ü 129	Ë 145	‘ 161	⌘ 177	⌚ 193	⌛ 209	β 225	± 241
2	0010	é 130	Ê 146	ó 162	⌘ 178	⌚ 194	⌛ 210	Γ 226	≥ 242
3	0011	â 131	ô 147	ú 163	⌘ 179	⌚ 195	⌛ 211	π 227	≤ 243
4	0100	À 132	È 148	⌘ 164	⌘ 180	⌚ 196	⌛ 212	Σ 228	∫ 244
5	0101	à 133	Ï 149	⌘ 165	⌘ 181	⌚ 197	⌛ 213	σ 229	∫ 245
6	0110	¶ 134	ü 150	³ 166	⌘ 182	⌚ 198	⌛ 214	μ 230	÷ 246
7	0111	ç 135	û 151	⌘ 167	⌘ 183	⌚ 199	⌛ 215	τ 231	≈ 247
8	1000	ê 136	Ï 152	Ï 168	⌘ 184	⌚ 200	⌛ 216	Φ 232	° 248
9	1001	ë 137	Ô 153	⌘ 169	⌘ 185	⌚ 201	⌛ 217	θ 233	• 249
A	1010	è 138	Û 154	⌘ 170	⌘ 186	⌚ 202	⌛ 218	Ω 234	· 250
B	1011	ï 139	ç 155	½ 171	⌘ 187	⌚ 203	■ 219	δ 235	√ 251
C	1100	î 140	£ 156	¼ 172	⌘ 188	⌚ 204	■ 220	∞ 236	∞ 252
D	1101	— 141	Û 157	¾ 173	⌘ 189	⌚ 205	■ 221	∅ 237	² 253
E	1110	À 142	Û 158	« 174	⌘ 190	⌚ 206	■ 222	€ 238	■ 254
F	1111	š 143	ƒ 159	» 175	⌘ 191	⌚ 207	■ 223	∩ 239	SP 255

	HEX	8	9	A	B	C	D	E	F
HEX	BIN	1000	1001	1010	1011	1100	1101	1110	1111
0	0000	Ç 128	É 144	á 160	⌘ 176	⌘ 192	⌘ 208	α 224	≡ 240
1	0001	ü 129	æ 145	í 161	⌘ 177	⌘ 193	⌘ 209	β 225	± 241
2	0010	é 130	Æ 146	ó 162	⌘ 178	⌘ 194	⌘ 210	Γ 226	≥ 242
3	0011	â 131	ø 147	ú 163	 179	† 195	⌘ 211	π 227	≤ 243
4	0100	ä 132	ö 148	ñ 164	⌘ 180	- 196	⌘ 212	Σ 228	∫ 244
5	0101	à 133	ò 149	Ñ 165	⌘ 181	+ 197	⌘ 213	σ 229	∫ 245
6	0110	â 134	û 150	ä 166	⌘ 182	† 198	⌘ 214	μ 230	÷ 246
7	0111	ç 135	ù 151	o 167	⌘ 183	† 199	† 215	τ 231	≈ 247
8	1000	ê 136	ÿ 152	¿ 168	⌘ 184	⌘ 200	+ 216	Φ 232	° 248
9	1001	ë 137	ÿ 153	¿ 169	⌘ 185	⌘ 201	⌘ 217	θ 233	• 249
A	1010	è 138	Û 154	¿ 170	 186	⌘ 202	⌘ 218	Ω 234	· 250
B	1011	ï 139	ø 155	½ 171	⌘ 187	⌘ 203	■ 219	δ 235	√ 251
C	1100	î 140	£ 156	¼ 172	⌘ 188	† 204	■ 220	∞ 236	∞ 252
D	1101	ì 141	ø 157	¿ 173	⌘ 189	- 205	■ 221	∅ 237	² 253
E	1110	Ë 142	Pl 158	« 174	⌘ 190	† 206	■ 222	€ 238	■ 254
F	1111	À 143	f 159	¤ 175	⌘ 191	⌘ 207	■ 223	∩ 239	SP 255

In the space page (page 254), the 7 × 7 font is defined as the default. When the 9 × 9 font is selected, character codes 80H to FFH are all spaces.)

HEX	8	9	A	B	C	D	E	F	
HEX	BIN	1000	1001	1010	1011	1100	1101	1110	1111
0	0000	ø	0	@	P	.	p		
		128	144	160	176	192	208	224	240
1	0001	δ	μ	!	1	A	Q	a	q
		129	145	161	177	193	209	225	241
2	0010	Đ	Þ	"	2	B	R	b	r
		130	146	162	178	194	210	226	242
3	0011	Ê	Ɔ	#	3	C	S	c	s
		131	147	163	179	195	211	227	243
4	0100	Ë	Û	\$	4	D	T	d	t
		132	148	164	180	196	212	228	244
5	0101	È	Ü	%	5	E	U	e	u
		133	149	165	181	197	213	229	245
6	0110	Ï	Ů	&	6	F	V	f	v
		134	150	166	182	198	214	230	246
7	0111	Î	Ý	'	7	G	W	g	w
		135	151	167	183	199	215	231	247
8	1000	Ï	Ÿ	(8	H	X	h	x
		136	152	168	184	200	216	232	248
9	1001	İ	±)	9	I	Y	i	y
		137	153	169	185	201	217	233	249
A	1010	Ó	÷	*	:	J	Z	j	z
		138	154	170	186	202	218	234	250
B	1011	ß	.	+	;	K	[k	{
		139	155	171	187	203	219	235	251
C	1100	Ö	.	.	<	L	\	l	
		140	156	172	188	204	220	236	252
D	1101	Ø	.	-	=	M]	m	}
		141	157	173	189	205	221	237	253
E	1110	.	.	.	>	N	-	n	~
		142	158	174	190	206	222	238	254
F	1111	ö	.	/	?	O	-	o	.
		143	159	175	191	207	223	239	255

In the space page (page 255), the 7 × 7 font is defined as the default. When the 9 × 9 font is selected, character codes 80H to FFH are all spaces.)

	HEX	8	9	A	B	C	D	E	F
HEX	BIN	1000	1001	1010	1011	1100	1101	1110	1111
0	0000	Ç 128	É 144	Á 150	.	.	H 208	224	240
1	0001	Ü 129	Æ 145	Í 151	.	.	I 209	225	241
2	0010	É 130	Æ 146	Ó 152	.	.		226	242
3	0011	Ä 131	Ö 147	Ú 153	.	.		227	243
4	0100	Ä 132	Ö 148	Ñ 154	.	.		228	244
5	0101	À 133	Ò 149	Ñ 155	À 181	.		229	245
6	0110	Å 134	Û 150	Ğ 166	À 182	ä 198		230	246
7	0111	Ç 135	Û 151	Ğ 167	À 183	Ä 199		231	247
8	1000	È 136	ÿ 152	¿ 168	ì 184	Ł 200		232	248
9	1001	Ë 137	Ö 153	.	ł 185	ŕ 201		233	249
A	1010	È 138	Û 154	.	ł 186	ł 202		234	250
B	1011	İ 139	ø 155	.	ŕ 187	ŕ 203		235	251
C	1100	Î 140	£ 156	.	ŕ 188	ł 204		236	252
D	1101	Ì 141	Ø 157	ì 173	ç 189	= 205		237	253
E	1110	Ä 142	Ş 158	.	.	ł 206		238	254
F	1111	Å 143	ş 159	Đ 175	.	.		239	255

International character set

Country Name	HEX DEC	ASCII code											
		23 35	24 36	40 64	5B 91	5C 92	5D 93	5E 94	6D 96	7B 123	7C 124	7D 125	7E 126
0 U.S.A.		#	\$	@	[\]	^	'	{		}	-
1 France		#	\$	à	°	ç	§	^	'	é	ù	è	~
2 Germany		#	\$	§	Ä	Ö	Ü	^	'	ä	ö	ü	ß
3 England		£	\$	@	[\]	^	'	{		}	-
4 Denmark I		#	\$	@	Æ	Ø	Å	^	'	æ	ø	å	-
5 Sweden		#	κ	É	Ä	Ö	Å	Ü	é	ä	ö	å	ü
6 Italy		#	§	@	°	\	é	^	ù	à	ò	è	ì
7 Spain		Pt	§	@	ì	Ñ	¿	^	'	ñ)	-	
8 Japan		#	\$	@	[¥]	^	'	{		}	-
9 Norway		#	κ	É	Æ	Ø	Å	Ü	é	æ	ø	å	ü
10 Denmark II		#	\$	É	Æ	Ø	Å	Ü	é	æ	ø	å	ü

Chapter 5

Commands

Command Notation

[Name]	The name of the command.
[Format]	The code sequence. ASCII indicates the ASCII equivalents. Hex indicates the hexadecimal equivalents. Decimal indicates the decimal equivalents. [] <i>k</i> indicates the contents of the [] should be repeated <i>k</i> times.
[Range]	Gives the allowable ranges for the parameters.
[Description]	Describes the function of the command.
[Notes]	Provides important information on setting and using the printer command, if necessary.
[Default]	Gives the default values, if any, for the command parameters.
[Reference]	Lists related commands.
[Example]	Provides examples using the command.

The numbers denoted by <>H are hexadecimal.

The numbers denoted by <>B are binary.

The numbers denoted by <> are decimal.

- NOTE: The phrase "beginning of a line" in command descriptions assumes that the following conditions have been met:
1. Print data, including spaces, is not in the current print buffer.
 2. The print position is not specified by the **ESC \$** or **ESC ** command.

The terms "horizontal motion units" and "vertical motion units" used in the descriptions of some commands are explained in the description of **GS P x y** on page 5-34.

Control Commands

LF

[Name] Print and line feed

[Format] ASCII LF
Hex 0A
Decimal 10

[Description] Prints the data in the print buffer and feeds one line based on the current line spacing.

[Note] This command sets the print position to the beginning of the line.

[Reference] **ESC 2, ESC 3**

FF

[Name] Print and eject slip paper

[Format] ASCII FF
Hex 0C
Decimal 12

[Description] Prints the data in print buffer and ejects the slip paper.

[Notes]

- The command is enabled only when slip paper is selected for printing.
- Paper ejection continues until the paper is completely ejected. When the slip ejection length has been set by **ESC C**, the specified length is ejected, regardless of the slip ejection sensor.
- After the slip is ejected, the printer selects the default paper type for **ESC c 0**.
- The slip is ejected in the forward direction only.

[Reference] **ESC c 0, ESC C**

CR

[Name] Carriage return

[Format] ASCII CR
Hex 0D
Decimal 13

[Description] When auto line feed is enabled, this command functions the same as LF. When auto line feed is disabled, this command prints the data in the print buffer and does not feed the paper.

[Note] Sets the print starting position to the beginning of the line

[Reference] **LF**

DLE EOT *n*

[Name] Real-time status transmission

[Format] ASCII DLE EOT *n*
Hex 10 04 *n*
Decimal 16 4 *n*

[Range] $1 \leq n \leq 5$

[Description] Transmits the selected printer status specified by *n* in real time, according to the following parameters:

- n* = 1: Transmit printer status
- n* = 2: Transmit off-line status
- n* = 3: Transmit error status
- n* = 4: Transmit paper roll sensor status
- n* = 5: Transmit slip paper status

- [Notes]
- The printer executes this command upon receiving it.
 - When transmitting status, the printer transmits only 1 byte without confirming the condition of the DSR signal.
 - This command is executed even when the printer is off-line, when the receive buffer is full, or when an error occurs.
 - The status is transmitted whenever the data sequence of <10>H<04>H<*n*> ($1 \leq n \leq 5$) is received. For example,
In ESC * *m n L n H [d] n L+256×*n* H, d1=<10>H, d2=<04>H, d3=<1>H*
 - This command should not be used within the data sequence of another command that consists of 2 or more bytes. For example,
If you attempt to transmit ESC 3 *n* to the printer, but DTR (DSR for the host computer) goes to MARK before *n* is transmitted and DLE EOT 4 interrupts before *n* is received, the code <10>H for DLE EOT 4 is processed as the code for ESC 3 <10>H.
 - This command is unavailable when using the ESC= (Select peripheral device) to select the printer to be disabled.
 - When Auto Status Back (ASB) is enabled using the GS a command, the status transmitted by the DLE EOT command and the ASB status must be differentiated.
 - If *n* is out of the specified range, the printer ignores this command.

n = 1: Printer status

Bit	Off/On	Hex	Decimal	Function
0	Off	00	0	Not used. Fixed to Off.
1	On	02	2	Not used. Fixed to On.
2	Off	00	0	Drawer kick-out signal is LOW (connector pin 3)
	On	04	4	Drawer kick-out signal is HIGH (connector pin 3)

Bit	Off/On	Hex	Decimal	Function
3	Off	00	0	On-line.
	On	08	8	Off-line.
4	On	10	16	Not used. Fixed to On.
5,6	-	-	-	Undefined.
7	Off	00	0	Not used. Fixed to Off.

$n = 2$: Off-line status

Bit	Off/On	Hex	Decimal	Function
0	Off	00	0	Not used. Fixed to Off.
1	On	02	2	Not used. Fixed to On.
2	Off	00	0	Cover is closed and the print head is closed.
	On	04	4	Cover is open or the print head is opened.
3	Off	00	0	Paper not being fed by the paper feed button.
	On	08	8	Paper is being fed by the paper feed button.
4	On	10	16	Not used. Fixed to On.
5	Off	00	0	No paper-end stop.
	On	20	32	Printing stops due to paper end.
6	Off	00	0	No error.
	On	40	64	Error occurs.
7	Off	00	0	Not used. Fixed to Off.

Bit 5: On (printing stops due to paper-end) when printing stops due to paper-end detected by the paper-end sensor or the paper near-end enabled by using the **ESC c 4**.

$n = 3$: Error status

Bit	Off/On	Hex	Decimal	Function
0	Off	00	0	Not used. Fixed to Off.
1	On	02	2	Not used. Fixed to On.
2	Off	00	0	No mechanical error.
	On	04	4	Mechanical error occurred.

Bit	Off/On	Hex	Decimal	Function
3	Off	00	0	No auto-cutter error.
	On	08	8	Auto-cutter error occurred.
4	On	10	16	Not used. Fixed to On.
5	Off	00	0	No unrecoverable error.
	On	20	32	Unrecoverable error has occurred
6	Off	00	0	No print head temperature error.
	On	40	64	Print head temperature error has occurred.
7	Off	00	0	Not used. Fixed to Off.

Bit 2: Mechanical errors include home position, carriage sensor, and slip ejection errors.

Bits 2 and 3: If these errors occur due to paper jams or the like, it is possible to recover by correcting the cause of the error and executing **DLE ENQ n** ($1 \leq n \leq 2$). If an error due to a circuit failure (e.g. wire break) occurs, it is impossible to recover.

Bit 6: If the print head temperature becomes high, bit 6 is transmitted until the print head temperature drops sufficiently. The printer automatically recovers from this error.

$n = 4$: Continuous paper sensor status

Bit	Off/On	Hex	Decimal	Function
0	Off	00	0	Not used. Fixed to Off.
1	On	02	2	Not used. Fixed to On.
2	Off	00	0	Paper roll near-end sensor: paper adequate.
	On	04	4	Paper near-end is detected by the paper roll near-end sensor.
3	Off	00	0	Paper roll near-end sensor: paper adequate.
	On	08	8	Paper near-end is detected by the paper roll near-end sensor.
4	On	10	16	Not used. Fixed to On.
5	Off	00	0	Paper roll sensor. Paper present.
	On	20	32	Paper roll end detected by paper roll sensor.

Bit	Off/On	Hex	Decimal	Function
6	Off	00	0	Paper roll sensor. Paper present.
	On	40	64	Paper roll end is detected by the paper roll sensor.
7	Off	00	0	Not used. Fixed to Off.

$n = 5$: Slip paper status

Bit	Off/On	Hex	Decimal	Function
0	Off	00	0	Not used. Fixed to Off.
1	On	02	2	Not used. Fixed to On.
2	Off	00	0	Slip paper selected.
	On	04	4	Slip paper not selected.
3	Off	00	0	Does not wait for slip paper insertion.
	On	08	8	Waits for slip paper insertion
4	On	10	16	Not used. Fixed to On.
5	Off	00	0	Slip is detected by slip insertion sensor
	On	20	32	Slip is not detected by slip insertions sensor
6	Off	00	0	Slip is detected by slip ejection sensor
	On	40	64	Slip is not detected by slip ejection sensor
7	Off	00	0	Not used. Fixed to Off.

Bit 2: There may be a time lag between receiving the paper selection command (ESC c 0) and selecting the slip paper. During this period, bit 2 remains 1.

Remains 0 (selected) until the slip is removed.

Bit 3: Becomes 0 (slip insertion is not waiting) just before loading slip paper, after detecting it.

Bit 5 and 6: Transmit the current status of the slip sensors.

[Reference] **DLE ENQ**, **ESC u**, **ESC v**, **GS ENQ**, **GS a**, **GS r**

DLE ENQ n

[Name]	Real-time request to printer			
[Format]	ASCII	DLE	ENQ	n
	Hex	10	05	n
	Decimal	16	5	n

[Range] $1 \leq n \leq 3$

[Description] The printer responds to a request from the host specified by n . The operations performed depend on the value of n , as follows:

$n = 1$: Restarts printing from the beginning of the line where the error occurred, after recovering from the error.

$n = 2$: Recovers from an error after clearing the receive and print buffers.

$n = 3$: Cancels the slip waiting status.

[Notes]

- The printer executes this command upon receiving it.
- This command is also executed when the printer is off line, the receive buffer is full, or an error occurs.
- The status is also transmitted whenever the data sequence of $\langle 10 \rangle H \langle 05 \rangle H \langle n \rangle$ ($1 \leq n \leq 3$) is received. For example,
In **ESC *m nL nH [d] nL+256×nH**, $d1 = \langle 10 \rangle H$, $d2 = \langle 05 \rangle H$, $d3 = \langle 1 \rangle$
- This command should not be used within the data sequence of another command that consists of two or more bytes. For example,
If you attempt to transmit **ESC 3 n** to the printer, but DTR (DSR for the host computer) goes to MARK before n is transmitted, and **DLE ENQ 2** interrupts before n is received, the code $\langle 10 \rangle H$ for **DLE ENQ 2** is processed as the code for **ESC 3** $\langle 10 \rangle H$.
- **DLE ENQ 1** starts printing from the line where an error occurred. This command is available only for errors that have the possibility of recovery, except print head temperature errors.
- When printer recovers from an error using **DLE ENQ 1**, and slip paper is selected, the printer ejects the slip completely and loads the paper. However, the printer ejects the slip and does not load paper only when the printer recovers from a slip ejection error.
- **DLE ENQ 2** enables the printer to recover from an error after clearing the data in the receive buffer and the print buffer. The printer retains the settings (by **ESC !**, **ESC 3**, etc.) in effect when the error occurred. The printer can be initialized completely by using this command and **ESC @**. This command is enabled only for errors that have the possibility of recovery, except for print head temperature errors.
- When printer recovers from an error using **DEL ENQ 2** with slip selected, it ejects the slip completely and goes to paper roll mode. Therefore, when printing on slip paper is to be continued, select slip mode again using **ESC c 0 4** after the slip is ejected.
- **DLE ENQ 3** is ignored except when the printer is in the slip waiting state. Therefore, be sure to use **DLE EOT 5** to check whether slip paper is selected and the printer is in the slip waiting state before executing **DLE ENQ 3**. After the printer is released from the slip waiting state, the paper roll is selected.
- When the slip waiting status is cancelled by **DLE ENQ 3**, the receive and print buffers are cleared.

- When the printer is disabled with ESC = (Select peripheral device), the error recovery functions (**DLE ENQ 1** and **DLE ENQ 2**) are enabled, and the other functions are disabled.
- If the value of *n* is out of the specified range, this command is ignored.

[Reference] **DLE EOT**

[Notes when the printer is used with the MICR reader]

- When the printer recovers from an error using **DLE ENQ 1**, and the MICR function is selected using **FS a 0**, the printer clears the print buffer, ejects the slip paper completely, and goes into the roll paper mode. Therefore, when personal check reading is to be continued, select the MICR function again using **FS a 0**.
- When the printer recovers from an error using **DEL ENQ 2** with the MICR function selected using **FS a 0**, the printer clears the receive and print buffers, ejects the slip completely, and goes to the roll paper mode. Therefore, when check reading is to be continued, select the MICR function again using **FS a 0**.
- **DLE ENQ 3** is ignored, except when the printer is in the slip or personal check waiting state using **DLE EOT 5** before executing **DLE ENQ 3**. Or be sure to confirm whether MICR function is selected and the printer is in the personal check waiting state using **DEL EOT BS 1**. After the printer is released from the slip or personal check waiting state, receipt and journal papers are selected.
- When the slip or personal check waiting status is cancelled by **DLE ENQ 3**, the receive and print buffers are cleared.
- This command is ignored while the printer transmits the reading results of MICR.

[Reference when the printer is used with the MICR reader]

DLE EOT BS

ESC SP *n*

[Name] Set right-side character spacing

[Format]	ASCII	ESC	SP	<i>n</i>
	Hex	1B	20	<i>n</i>
	Decimal	27	32	<i>n</i>

[Range] $0 \leq n \leq 255$

[Description] Sets the character spacing for the right side of the character using the horizontal motion units.

- Right-side character spacing is [*n* × (horizontal motion units)] inches.

[Notes]

- The right-side character spacing for double-width mode is twice the normal value.
- If *n* is out of the specified range, this command is ignored.

[Default] *n*=0

[Reference] **GS P**

ESC ! *n*

[Name] Select print mode(s)

[Format] ASCII ESC ! *n*
Hex 1B 21 *n*
Decimal 27 33 *n*

[Range] $0 \leq n \leq 255$

[Description] Selects print mode(s) using *n* as follows:

Bit	Off/On	Hex	Decimal	Function
0	Off	00	0	9 × 9 font selected.
	On	01	1	7 × 9 font selected.
1, 2	-	-	-	Undefined.
3	Off	00	0	Emphasized mode not selected.
	On	08	8	Emphasized mode selected.
4	Off	00	0	Double-height mode not selected.
	On	10	16	Double-height mode selected.
5	Off	00	0	Double-width mode not selected.
	On	20	32	Double-width mode selected.
6	-	-	-	Undefined.
7	Off	00	0	Underline mode not selected.
	On	80	128	Underline mode selected.

- [Notes]
- When both double-height and double-width modes are selected, quadruple size characters are printed.
 - Bidirectional printing may cause misalignment between the upper and lower halves of the characters during double-height enlarged printing. Therefore, it is better to select unidirectional printing (using **ESC U**) for double-height enlarged printing.
 - In underline mode, some characters may be difficult to read because the underline overlaps the lowest dots in the characters.

[Default] $n = 0$ or 1 depending on the DIP switch setting.

[Reference] **ESC E**, **ESC -**

ESC \$ nL nH

[Name]	Set absolute print position			
[Format]	ASCII	ESC	\$	nL nH
	Hex	1B	24	nL nH
	Decimal	27	36	nL nH
[Range]	$0 \leq nL \leq 255$ $0 \leq nH \leq 255$			
[Description]	Sets the distance from the beginning of the line to the position at which subsequent characters are to be printed. <ul style="list-style-type: none">• The distance from the beginning of the line to the print position is $[(nL + nH \times 256) \times (\text{horizontal motion unit})]$ inches.			
[Note]	<ul style="list-style-type: none">• Settings outside the specified printable area are disabled.			
[Reference]	ESC \, GS P			

ESC % n

[Name]	Select/cancel user-defined character set			
[Format]	ASCII	ESC	%	n
	Hex	1B	25	n
	Decimal	27	37	n
[Range]	$0 \leq n \leq 255$			
[Description]	Selects or cancels the user-defined character set. When the Least Significant Bit (LSB) is 0, the user-defined character set is canceled and the internal character set is enabled. When the LSB is 1, the user-defined character set is selected.			
[Notes]	<ul style="list-style-type: none">• The user-defined character and the downloaded bit image cannot be defined simultaneously.			
[Default]	$n = 0$			
[Reference]	ESC &			

ESC & y $c1$ $c2$ [X [d] $y \times x$] $c2 - c1 + 1$

[Name]	Define user-defined characters			
[Format]	ASCII	ESC	&	y $c1$ $c2$ [x $d1 \dots d(y \times x)$] $c2 - c1 + 1$
	Hex	1B	26	y $c1$ $c2$ [x $d1 \dots d(y \times x)$] $c2 - c1 + 1$
	Decimal	27	38	y $c1$ $c2$ [x $d1 \dots d(y \times x)$] $c2 - c1 + 1$
[Range]	$y = 2$ $32 \leq c1 \leq c2 \leq 126$ $0 \leq x \leq 12$ (9×9 font) $0 \leq x \leq 9$ (7×9 font) $0 \leq d1 \dots dy \times x \leq 255$			
[Description]	Defines user-defined characters.			

- y specifies the number of bytes in the vertical direction.
- $c1$ specifies the beginning character code for the definition, and $c2$ specifies the final code. For only one character, use $c1 = c2$.
- The allowable character code range is from decimal code 32 to 126. The maximum number of user-defined characters depends on the receive buffer capacity. (See the DIP switch table for instructions on setting the receive buffer capacity.) For 2K bytes, the maximum is 23, for 32K bytes, 71.
- When the maximum number of user-defined characters is defined, it is possible to redefine user-defined characters for the defined character codes, but not for new character codes.
- x specifies the number of dots in the horizontal direction.
- d is the dot data for the characters. The dot pattern is in the horizontal direction from the left side. Any remaining dots on right side are blank.

[Notes]

- Horizontally adjacent dots cannot be printed.
- Only top bit in secondary data bytes in vertical direction is valid.
- After user-defined characters are defined, they are available until another definition is made; **ESC @** or **GS *** is executed; the printer is reset; or the power is turned off.
- A user-defined character and a downloaded bit image cannot be defined simultaneously. When this command is executed, the downloaded bit image is cleared.
- If the values of y , $c1$, $c2$, or x are out of the specified range, the printer ignores the command and processes the following data as normal data.

[Default] The internal character set

[Reference] **ESC %**, **ESC ?**

[Example]

7 × 9 font when the dot pattern for code 20H is defined as shown below.

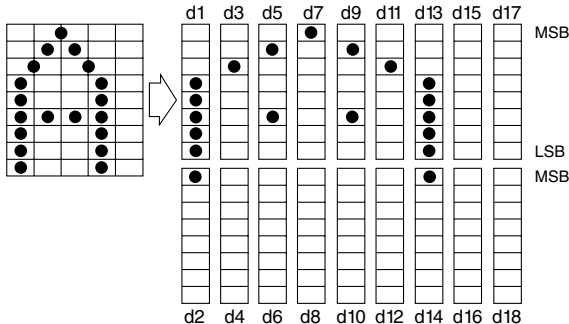

When the dot pattern for code 20H is defined as shown above.

ESC & y c1 c2 X d1 d2 d3 d4 d5 d6 d7 d8 d9 d10 d11 d12 d13 d14
 Code (Hexadecimal) 1B 26 02 20 20 07 1F 80 20 00 44 00 80 00 44 00 20 00 1F 80

The corresponding bit is 1 when printing and 0 when not printing.

ESC * m nL nH [d] $nL + 256 \times nH$

[Name]	Select bit-image mode				
[Format]	ASCII	ESC	*	m nL nH [d] $nL + 256 \times nH$	
	Hex	1B	2A	m nL nH [d] $nL + 256 \times nH$	
	Decimal	27	42	m nL nH [d] $nL + 256 \times nH$	
[Range]	$m = 0, 1$				
	$0 \leq nL \leq 255$				
	$0 \leq nH \leq 3$				
	$0 \leq d \leq 255$				

[Description] Selects a bit-image mode using m for the number of dots specified by nL and nH , as follows:

m	No. of Vert. Dots	Horizontal Direction		Maximum number of dots	
		Dot Density	Adjacent Dot	Paper Roll	Slip
0	8	Single Density	Permitted	180	400
1	8	Double Density	Prohibited	360	800

- [Notes]
- Divide the number of dots to be printed by 256. The integer answer is nH and the remainder is nL . Therefore, the number of dots in the horizontal direction is calculated by $nL + 256 \times nH$.
 - If the bit-image data input exceeds the number of dots to be printed on a line, the excess data is ignored.
 - d indicates the bit-image data. Set a corresponding bit to 1 to print a dot or to 0 to not print a dot.
 - If the values of m and nH are out of the specified range, the following data is processed as normal data.
 - After printing a bit image, the printer returns to normal mode.
 - The relationship between the image data and the dots to be printed is shown below:

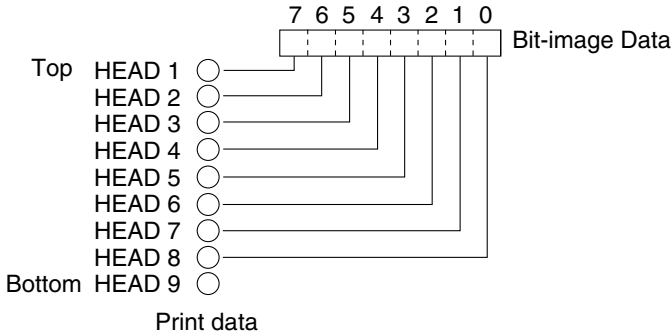

ESC - *n*

[Name] Turn underline mode on/off

[Format] ASCII ESC - *n*
 Hex 1B 2D *n*
 Decimal 27 45 *n*

[Range] $n = 0, 1, 48, 49$

[Description] Turns underline mode on or off, based on the following values of *n*.

<i>n</i>	Function
0, 48	Turns off underline mode
1, 49	Turns on underline mode

[Notes] • This command and **ESC !** turn underline mode on or off in the same way.
 • If *n* is out of the specified range, this command is ignored.

[Default] $n = 0$

[Reference] **ESC !**

ESC 2

[Name] Select 1/6-inch line spacing

[Format] ASCII ESC 2
 Hex 1B 32
 Decimal 27 50

[Description] Selects 1/6-inch line spacing.

[Note] This command is available only for paper type(s) selected by **ESC c 1**.

[Reference] **ESC c 1**

ESC 3 *n*

[Name] Set line spacing

[Format] ASCII ESC 3 *n*
 Hex 1B 33 *n*
 Decimal 27 51 *n*

[Range] $0 \leq n \leq 255$

[Description] Sets the line spacing to [*n* x vertical motion unit] inches.

[Note] This command is available only for paper type(s) selected by **ESC c 1**.

[Default] $n = 24$ (1/6 inch)

[Reference] **ESC c 1, GS P**

ESC <

[Name] Return home

[Format] ASCII ESC <
Hex 1B 3C
Decimal 27 60

[Description] Moves the printing head to the leftmost position, then moves it to the rightmost position.

- [Notes]
- The leftmost end is detected by the home position sensor.
 - Since the home position is detected when this command is executed, the printing position may shift after this command is executed.

ESC = *n*

[Name] Set device

[Format] ASCII ESC = *n*
Hex 1B 3D *n*
Decimal 27 61 *n*

[Range] $0 \leq n \leq 255$

[Description] Selects device to which host computer sends data, using *n* as follows:

Bit	Off/On	Hex	Decimal	Function
0	Off	00	0	Printer disabled.
	On	01	1	Printer enabled
1	Off	00	0	Customer display disabled.
	On	02	2	Customer display enabled.
2-7	-	-	-	Undefined.

- [Notes]
- When the printer is disabled, it ignores all data except for error-recovery commands (**DLE ENQ 1**, **DLE ENQ 2**) until it is enabled by this command.
 - Even if the printer is disabled, it may go off-line due to printer operation.

[Default]

- When turning on the printer:

Direct Connection Customer Display Status	<i>n</i>
Customer display is recognized (*1)	2
Customer display is not recognized (*1)	1

- When executing **ESC @**:

Default values set by **ESC @** are as follows, depending on the value set by **ESC =** just before processing **ESC @** and on the setting of DIP switch 1-6:

Direct Connection Customer Display Status Default Value to be Set		<i>n</i>		
		1	2	3
After ESC @ Processing	When customer display is connected (*1)	1	2(*2)	2
	When customer display is not connected (*1)	1	2(*2)	1

(*1) Depending on the setting of DIP switch 1-6.

(*2) The printer is disabled and it does not process **ESC @**; therefore, the **ESC =** setting is changed.

ESC ? *n*

[Name] Cancel user-defined characters

[Format] ASCII ESC ? *n*
 Hex 1B 3F *n*
 Decimal 27 63 *n*

[Range] $32 \leq n \leq 126$

[Description] Cancels user-defined characters.

- [Notes]
- This command cancels the pattern defined for the character code specified by *n*. After the user-defined characters is cancelled, the corresponding pattern for the internal character is printed.
 - If a user-defined character has not been defined for the specified character code, the printer ignores this command.
 - If *n* is out of the range, this command is ignored.

[Reference] **ESC &**, **ESC %**

ESC @

[Name] Initialize printer

[Format] ASCII ESC @
 Hex 1B 40
 Decimal 27 64

[Description] Clears the data in the print buffer and resets the printer mode to the mode that was in effect when the power was turned on.

- [Notes]
- The DIP switch settings are not checked again.
 - The data in the receive buffer is not cleared.
 - When this command is executed in slip mode, the printer ejects the slip and switches from slip mode to paper roll mode.

ESC C *n*

[Name] Set slip paper eject length

[Format]	ASCII	ESC	C	<i>n</i>
	Hex	1B	43	<i>n</i>
	Decimal	27	67	<i>n</i>

[Range] $0 \leq n \leq 255$

[Description] Sets the eject length setting for slip paper to *n* lines.

[Notes]

- When $n = 0$, the eject length setting for slip paper is cancelled.
- Specified eject length doesn't change even if line spacing changes.
- The maximum eject length that can be set is 40 inches. If the specified amount exceeds 40 inches, the eject length is automatically set to 40 inches.

[Default] $n = 0$

[Reference] **FF**, **ESC 2**, **ESC 3**

ESC E *n*

[Name] Turn emphasized mode on/off

[Format]	ASCII	ESC	E	<i>n</i>
	Hex	1B	45	<i>n</i>
	Decimal	27	69	<i>n</i>

[Range] $0 \leq n \leq 255$

[Description] Turns emphasized mode on or off.

[Notes]

- When the LSB of *n* is 0, emphasized mode is turned off.
- When the LSB of *n* is 1, emphasized mode is turned on.
- 2-pass printing is slower in emphasized mode.
- This command and **ESC !** turn on and off emphasized mode in the same way. Be careful when this command is used with **ESC !**.
- Only the lowest bit of *n* is enabled.

[Default] $n = 0$

[Reference] **ESC !**

ESC G *n*

[Name] Turn on/off double-strike mode

[Format]	ASCII	ESC	G	<i>n</i>
	Hex	1B	47	<i>n</i>
	Decimal	27	71	<i>n</i>

[Range] $0 \leq n \leq 255$

[Description] Turns double-strike mode on or off.

[Notes]

- When the LSB of *n* is 0, double-strike mode is turned off.
- When the LSB of *n* is 1, double-strike mode is turned on.
- Printer output is the same in double-strike and in emphasized.
- Only the lowest bit of *n* is enabled.

[Default] $n = 0$
[Reference] **ESC E**

ESC J n

[Name] Print and feed paper

[Format]	ASCII	ESC	J	n
	Hex	1B	4A	n
	Decimal	27	74	n

[Range] $0 \leq n \leq 255$

[Description] Prints the data in the print buffer and feeds the paper [n x vertical motion unit] inches.

[Notes]

- After printing is completed, this command sets the print starting position to the beginning of the line.
- The maximum paper feed amount is 40 inches. If the specified amount exceeds 40 inches, the paper feed amount is automatically set to 40 inches.

[Reference] **GS P**

ESC K n

[Name] Print and reverse feed

[Format]	ASCII	ESC	K	n
	Hex	1B	4B	n
	Decimal	27	75	n

[Range] $0 \leq n \leq 255$

[Description] Prints the data in the print buffer and feeds the paper n x vertical motion unit inches in the reverse direction

[Notes]

- Sets the print starting position to the beginning of the line.
- This command must not be issued continuously more than two times.
- If n is out of the specified range or if the paper feed amount exceeds 1/6 inch, the printer prints the data and does not feed the paper.
- If the paper gets out of the slip sensor during slip printing, the printer prints the data and does not feed the paper.
- Reverse direction paper feeding causes the following problems
 - 1 Paper feed pitch is incorrect
 - 2 Printer noise is louder than normal.
 - 3 The paper may rub against the ribbon and become dirty.

[Reference] **GS P**

ESC R *n*

[Name] Select an international character set

[Format] ASCII ESC R *n*
 Hex 1B 52 *n*
 Decimal 27 82 *n*

[Range] $0 \leq n \leq 10$

[Description] Selects an international character set *n* from the following table:

<i>n</i>	Character set
0	U.S.A.
1	France
2	Germany
3	U.K.
4	Denmark I
5	Sweden
6	Italy
7	Spain
8	Japan
9	Norway
10	Denmark II

[Note] If the value of *n* is out of specified range, printer ignores the command.

[Default] *n* = 0

[Reference] *Character Code Tables*

ESC U *n*

[Name] Turn on/off unidirectional printing mode

[Format] ASCII ESC u *n*
 Hex 1B 55 *n*
 Decimal 27 85 *n*

[Range] $0 \leq n \leq 255$

[Description] Turns unidirectional printing mode on or off
When the LSB of *n* is 0, turn on unidirectional printing mode.
When the LSB of *n* is 1, turn off unidirectional printing mode and turn on bidirectional printing mode.

- [Notes]
- When unidirectional printing mode is turned on, the printer prints from left to right.
 - To avoid horizontal printing misalignment, unidirectional printing mode should be used.
 - Only the lowest bit of n is enabled.
- [Default] $n = 0$

ESC \ nL nH

- [Name] Set relative print position
- [Format]
- | | | | |
|---------|-----|----|-----------|
| ASCII | ESC | \ | nL nH |
| Hex | 1B | 5C | nL nH |
| Decimal | 27 | 92 | nL nH |
- [Range] $0 \leq nL \leq 255$
 $0 \leq nH \leq 255$

[Description] Sets the print starting position based on the current position.

- [Notes]
- Use the supplement of n for setting n pitch movement to the left:
 $-n$ pitch = $65536 - n$
 - The print starting position is $[(nL + nH \times 256) \times (\text{horizontal motion unit})]$ inches calculated from the current position.
 - Any value that falls outside the printable area is ignored.

[Reference] ESC \$, GS P

ESC a n

- [Name] Select justification
- [Format]
- | | | | |
|---------|-----|----|-----|
| ASCII | ESC | a | n |
| Hex | 1B | 61 | n |
| Decimal | 27 | 97 | n |
- [Range] $0 \leq n \leq 2, 48 \leq n \leq 50$

[Description] Aligns all the data in one line to the specified position.

n selects the type of justification as follows:

n	Justification
0, 48	Left justification
1, 49	Centering
2, 50	Right justification

- [Notes]
- Command is enabled only when input at the beginning of the line.
 - If the n is outside the specified range, the printer ignores the command.
 - Spaces set by ESC \$ and ESC \ are all justified.

[Default] $n = 0$

[Example]

Left justification	Centering	Right justification
ABC	ABC	ABC
ABCD	ABCD	ABCD
ABCDE	ABCDE	ABCDE

ESC c 0 n

[Name]	Select paper type(s) for printing				
[Format]	ASCII	ESC	c	0	<i>n</i>
	Hex	1B	63	30	<i>n</i>
	Decimal	27	99	48	<i>n</i>

Range 1 *n* 4

[Description] Selects the type of paper for printing, using *n* as follows:

Bit	Off/On	Hex	Decimal	Function
0	Off	00	0	Paper roll disabled.
	On	01	1	Paper roll enabled.
1	Off	00	0	Paper roll disabled.
	On	02	2	Paper roll enabled.
2	Off	00	0	Slip paper disabled.
	On	04	4	Slip paper enabled.
3-7	-	-	-	Undefined.

- [Notes]
- This command is available only when input at the beginning of a line.
 - Slip paper and paper roll cannot be selected simultaneously.
 - When this command is input, the printer executes the following:
 - If paper roll is selected, a previously selected slip paper is cancelled out and ejected.
 - If a slip was previously selected and is selected again, no operation is executed.
 - If paper roll was previously selected, and then slip paper is selected, the printer waits for the slip paper to be loaded.
 - If the value of *n* is out of the specified range, the printer ignores the command.
 - When either bit 0 or 1 is 1, the paper roll is selected.

[Default] *n* = 3

ESC c 1 *n*

[Name] Select paper type(s) for command settings

[Format] ASCII ESC c 1 *n*
 Hex 1B 63 31 *n*
 Decimal 27 99 49 *n*

[Range] $1 \leq n \leq 7$

Bit	Off/On	Hex	Decimal	Function
0	Off	00	0	Paper roll disabled.
	On	01	1	Paper roll enabled.
1	Off	00	0	Paper roll disabled.
	On	02	2	Paper roll enabled.
2	Off	00	0	Slip paper disabled.
	On	04	4	Slip paper enabled.
3-7	-	-	-	Undefined.

[Notes] • If the value of *n* is out of the specified range, the printer ignores the command.
 • When either 0 or 1 is 1, the paper roll is selected.

[Default] $n = 7$

[Reference] **ESC 2, ESC 3**

ESC c 4 *n*

[Name] Select paper sensor(s) to stop printing

[Format] ASCII ESC c 4 *n*
 Hex 1B 63 34 *n*
 Decimal 27 99 52 *n*

[Range] $0 \leq n \leq 255$

[Description] Selects the paper sensor(s) used to stop printing when a paper-end is detected, using *n* as follows:

Bit	Off/On	Hex	Decimal	Function
0	Off	00	0	Paper roll near end sensor disabled.
	On	01	1	Paper roll near end sensor enabled.
1	Off	00	0	Paper roll near end sensor disabled.
	On	02	2	Paper roll near end sensor enabled.

Bit	Off/On	Hex	Decimal	Function
2	Off	00	0	Paper roll sensor disabled.
	On	02	4	Paper roll sensor enabled.
3	Off	00	0	Paper roll sensor disabled.
	On	08	8	Paper roll sensor enabled.
4	Off	00	0	Slip insertion sensor disabled.
	On	10	16	Slip insertion sensor enabled.
5	Off	00	0	Slip insertion sensor disabled.
	On	20	32	Slip insertion sensor enabled.
6-7	-	-	-	Undefined.

- [Notes]
- When a paper sensor is enabled with this command, printing is stopped only when the corresponding paper is selected for printing.
 - It is possible to select multiple sensors for print control to stop printing. Then if any sensor detects a paper end, the printer stops printing.
 - When a paper end is detected, printing is stopped after printing the current line and feeding the paper.
 - When a paper-end is detected by the paper roll sensor, the printer goes off-line after printing stops.
 - When the slip insertion sensor detects a paper-end, the printer ejects the paper after printing as much data as possible and enters the paper waiting state.

[Default] $n = 12$

ESC c 5 *n*

[Name]	Enable/disable panel buttons				
[Format]	ASCII	ESC	c	5	<i>n</i>
	Hex	1B	63	35	<i>n</i>
	Decimal	27	99	53	<i>n</i>

[Range] $0 \leq n \leq 255$

[Description] Enables or disables the panel buttons.

- When the LSB of *n* is 0, the panel buttons are enabled.
- When the LSB of *n* is 1, the panel buttons are disabled.

- [Notes]
- When the panel buttons are disabled, no buttons on the panel are usable. Therefore, paper can be fed with the panel buttons only when the printer cover is open.
 - Only the lowest bit of *n* is valid.

[Default] $n = 0$

ESC d *n*

[Name] Print and feed *n* lines

[Format]	ASCII	ESC	d	<i>n</i>
	Hex	1B	64	<i>n</i>
	Decimal	27	100	<i>n</i>

[Range] $0 \leq n \leq 255$

[Description] Prints the data in the print buffer and feeds *n* lines.

[Notes]

- This command sets the print starting position to the beginning of the line.
- The maximum paper feed amount is 40 inches. If the specified amount exceeds 40 inches, the paper feed amount is automatically set to 40 inches.

[Reference] **ESC 2, ESC 3, ESC e**

ESC e *n*

[Name] Print and reverse feed *n* lines

[Format]	ASCII	ESC	e	<i>n</i>
	Hex	1B	65	<i>n</i>
	Decimal	27	101	<i>n</i>

[Range] $0 \leq n \leq 255$

[Description] Prints the data in the print buffer and feeds *n* lines in the reverse direction.

[Notes]

- This command sets the print starting position to the beginning of the line.
- If the value of *n* is out of the specified range or if the *n* line feed amount exceeds 1/6 inch, the printer prints the data and does not feed the paper.
- Paper feeding in the reverse direction causes the following problems:
 - Paper feed pitch is incorrect.
 - Printer noise is louder than normal.
 - The paper may rub against the ribbon and become dirty.

[Reference] **ESC 2, ESC 3, ESC d**

ESC f *t1 t2*

[Name] Set slip paper waiting time

[Format]	ASCII	ESC	f	<i>t1</i>	<i>t2</i>
	Hex	1B	66	<i>t1</i>	<i>t2</i>
	Decimal	27	102	<i>t1</i>	<i>t2</i>

[Range] $0 \leq t1 \leq 15$

$0 \leq t2 \leq 64$

[Description]	Sets the time that the printer waits for slip paper to be inserted and the time from insertion of the slip to the start of printing.
[Notes]	<ul style="list-style-type: none"> • $t1$ specifies the wait time for slip paper to be inserted. • $t2$ specifies time from insertion of the slip to the start of printing. • This command sets the slip paper wait time to $[t1 \times 1]$ minutes. If slip paper is not inserted within this time, the printer cancels slip paper mode and selects the default paper type for ESC c 0. • When $t1$ is set to 0, the printer waits until slip paper is inserted. • The printer starts operation $[t2 \times 0.1]$ seconds after detecting a slip. • When either $t1$ or $t2$ is out of the specified range, this command is ignored and the previously set value is not changed. • Using DLE ENQ 3 cancels the slip waiting state. The data in the receive buffer and the print buffer are cleared in this time. • For the following notes, assume that ESC c 4 is set to stop printing when the absence of slip paper is detected: <ul style="list-style-type: none"> If the printer is in paper-end and enters the slip waiting state by feeding a slip with the FEED button, there is no limit on the slip waiting time if the printer is not at the beginning of a line. If the printer is in a paper-end and enters the slip waiting state by attempting to print double-height characters on the last line of the slip, there is no limit on the slip waiting time. When the slip waiting time is set using ESC f t1 t2 and when printing stops because paper-end is enabled using ESC c 4 n, it is desirable to print on the remaining slip paper while checking the slip status using GS r 3.
[Default]	$t1 = 0, t2 = 10$

ESC i

[Name]	Execute partial cut (one point left uncut)		
[Format]	ASCII	ESC	i
	Hex	1B	69
	Decimal	27	105
[Description]	Executes a partial cut with one point left uncut.		
[Notes]	<ul style="list-style-type: none"> • In standard mode, this command is enabled only when input at the beginning of a line. • This command is available only when paper roll is selected for printing by ESC c 0. 		
[Reference]	ESC m		

ESC m

[Name]	Partial cut (three portions left uncut)		
[Format]	ASCII	ESC	m
	Hex	1B	6D
	Decimal	27	109

- [Description] Executes partial cut of the paper roll, with three portions left uncut.
- [Notes]
- This command is available only when input at the beginning of a line.
 - This command is available only when the paper roll is selected for printing by **ESC c 0**.

[Reference] **ESC i**

ESC o

[Name] Stamp

[Format]

ASCII	ESC	o
Hex	1B	6F
Decimal	27	111

[Description] Executes stamp printing on the paper roll.

- [Notes]
- Command is available only when input at the beginning of a line.
 - This command is available only when the paper roll is selected for printing by **ESC c 0**.

ESC p *m t1 t2*

[Name] Generate pulse

[Format]

ASCII	ESC	p	<i>m t1 t2</i>
Hex	1B	70	<i>m t1 t2</i>
Decimal	27	112	<i>m t1 t2</i>

[Range]

m = 0, 1, 48, 49

$0 \leq t1 \leq 255$

$0 \leq t2 \leq 255$

[Description] Outputs pulse specified by *t1* and *t2* to connector pin *m* as follows:

<i>m</i>	Connector pin
0, 48	Drawer kick-out connector pin 2
1, 49	Drawer kick-out connector pin 5

- [Notes]
- The pulse ON time is [*t1* × 10] ms and the OFF time is [*t2* × 10] ms.
 - When *t2* < *t1*, the printer processes *t2* as *t1*.
 - If *m* is outside the specified range, the printer ignores this command and the following data is processed as normal data.

ESC t *n*

[Name] Select character code table

[Format]

ASCII	ESC	t	<i>n</i>
Hex	1B	74	<i>n</i>
Decimal	27	116	<i>n</i>

[Range] $0 \leq n \leq 5, 254 \leq n \leq 255$

[Description] Selects a page n from the character code table.

n	Page	
0	0	PC437 (U.S.A., Standard Europe)
1	1	(Katakana)
2	2	PC850 (Multilingual)
3	3	PC860 (Portuguese)
4	4	PC863 (Canadian-French)
5	5	PC865 (Nordic)
254	Space page	
255	Space page	

[Note] If n is outside the specified range, the printer ignores this command.

[Default] $n = 0$

[Reference] *Character Code Tables*

ESC **u** n

[Name] Transmit peripheral device status

[Format] ASCII ESC **u** n
Hex 1B 75 n
Decimal 27 117 n

[Range] $n = 0, 48$

[Description] Transmits the status of connector pin n upon receiving this command, using n as follows:

n	Connector pin
0, 48	Drawer kick-out connector pin 3

- [Notes]
- When the connector is not used, the value of bit 0 is always 1.
 - When DTR/DSR control is selected, the printer transmits only 1 byte after confirming that the host is ready to receive data (DSR signal is SPACE). If the host computer is not ready to receive data (DSR signal is MARK), the printer keeps waiting until the host is ready. When XON/XOFF control is selected, the printer transmits only 1 byte without checking the DSR signal.
 - This command is executed when the data is processed in the receive buffer. Therefore, there may be a time lag between receiving the command and transmitting the status, depending on the receive buffer status.

- When Auto Status Back (ASB) is enabled using **GS a**, the status transmitted by **ESC u** and the ASB status must be differentiated.
- If *n* is out of the specified range, the printer ignores this command.
- The status to be transmitted is shown in the table below.

Bit	Off/On	Hex	Decimal	Function
0	Off	00	0	Drawer kick-out connector pin 3 signal is LOW.
	On	01	1	Drawer kick-out connector pin 3 signal is HIGH.
1	-	-	-	Undefined
2	Off	00	0	Slip paper disabled
	On	04	4	Slip paper enabled
3	-	-	-	Undefined.
4	Off	00	0	Not used. Fixed to Off.
5. 6	-	-	-	Undefined.
7	Off	00	0	Not used. Fixed to Off.

[Reference] **DLE EOT, GS ENQ, GS a, GS r**

ESC v

[Name] Transmit paper sensor status

[Format] ASCII ESC v
Hex 1B 76
Decimal 27 118

[Description] Transmits the current paper sensor status upon receiving this command.

- [Notes]
- When DTR/DSR control is selected, the printer transmits only 1 byte after confirming that the host is ready to receive data (DSR signal is SPACE).
 - If the host computer is not ready to receive data (DSR signal is MARK), the printer waits until the host is ready. When XON/XOFF control is selected, the printer transmits only 1 byte without checking the DSR signal.
 - The 1 byte status data is transmitted after printing and paper feed operation completely stop (transmit timing differs from **ESC u**, **GS I**, and **GS r**).

- This command is executed when the data is processed in the receive buffer. Therefore, there may be a time lag between receiving the command and transmitting the status, depending on the receive buffer status.
- When Auto Status Back (ASB) is enabled using **GS a**, the status transmitted by **ESC v** and the ASB status must be differentiated.
- The status to be transmitted is shown in the table below.

Bit	Off/On	Hex	Decimal	Function
0	Off	00	0	Roll near-end sensor: paper adequate
	On	01	1	Roll near-end sensor: paper near end.
1	Off	00	0	Roll near-end sensor: paper adequate
	On	02	2	Roll near-end sensor: paper near end.
2	Off	00	0	Roll sensor: paper present.
	On	04	4	Roll sensor: paper not present.
3	Off	00	0	Roll sensor: paper present.
	On	08	8	Roll sensor: paper not present.
4	Off	00	0	Not used. Fixed to OFF.
5	Off	00	0	Slip is detected by slip insertion sensor.
	On	20	32	Slip is not detected by slip insertion sensor.
6	Off	00	0	Slip ejection sensor: paper present.
	On	40	64	Slip ejection sensor: paper not present.
7	Off	00	0	Not used. Fixed to OFF.

[Reference] **DLE EOT, GS ENQ, GS a, GS r**, *Paper Specifications*

ESC { *n*

[Name] Turns on/off upside-down printing mode

[Format] ASCII ESC { *n*
Hex 1B 7B *n*
Decimal 27 123 *n*

[Range] $0 \leq n \leq 255$

[Description] Turns upside-down printing mode on or off.

- When the LSB of *n* is 0, upside-down printing mode is turned off.
- When the LSB of *n* is 1, upside-down printing mode is turned on.

- [Notes]
- In upside-down printing mode, the printer rotates the line to be printed by 180° and then prints it.
 - This command is enabled only when input at the beginning of a line.
 - Only the lowest bit of n is effective.

[Default] $n = 0$

[Example]

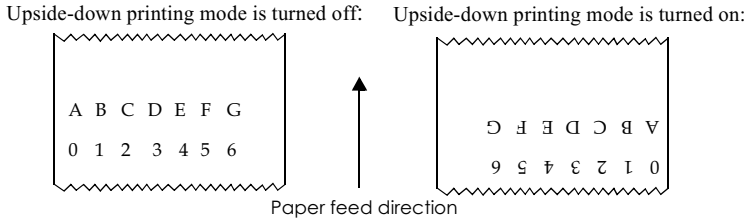

GS ENQ

[Name] Real-time printer status transmission

[Format] ASCII GS ENQ

Hex 1D 05

Decimal 29 5

[Description] Transmits status of the printer in real time.

- [Notes]
- The printer transmits only 1 byte without checking the DSR signal.
 - This command is also available in the off-line state, in the receive buffer full state, and in an error state.
 - The printer status is transmitted whenever the data sequence of <1D>H<05>H is received.

Example:

In ESC p m $t1$ $t2$: $t1 = <1D>H$, $t2 = <05>H$

In ESC * m nL nH [d] $nL + 256 \times nH$: $d1 = <1D>H$, $d2 = <05>H$

- This command should not be used within the data sequence of another command that consists of two or more bytes.

Example:

- If you attempt to transmit ESC 3 n to the printer, be sure to transmit n before transmitting GS ENQ regardless of the condition of the DTR signal (DSR for the host computer). If GS ENQ interrupts before n is received, n is processed as <1D>H.
- The command should not be used with handshaking of 7-bit data word length and XON/XOFF control. Otherwise, the status transmitted using this command cannot be differentiated from the XON/XOFF codes.
 - When Auto Status Back (ASB) is enabled using GS a, the status transmitted by GS ENQ and the ASB status must be differentiated.

Bit	Off/On	Hex	Decimal	Function
0	Off	00	0	Roll near-end sensor: paper adequate
	On	01	1	Roll near-end sensor: paper near end.
1	Off	00	0	Roll near-end sensor: paper adequate
	On	02	2	Roll near-end sensor: paper near end.
2	Off	00	0	Cover closed.
	On	04	4	Cover open.
3	Off	00	0	On-line.
	On	08	8	Off-line.
4	Off	00	0	Drawer kick-out connector pin 3: LOW.
	On	10	16	Drawer kick-out connector pin 3: HIGH
5	Off	00	0	Slip insertion sensor: paper present.
	On	20	32	Slip insertion sensor: paper not present.
6	Off	00	0	No error has occurred.
	On	40	64	Error has occurred.
7	Off	00	0	Not used. Fixed to 1.

Bit 3: Becomes 1 when printer off-line due to paper-end stop or cover-open.

Bit 6: Becomes 1 when an error has occurred due to auto-cutting, home position detection, carriage detection, slip ejection detection, or print head high temperature error.

[Reference] DLE EOT, ESC u, ESC v, GS a, GS r.

GS * x y [d] x×y×8

[Name] Define downloaded bit image

[Format] ASCII GS * x y [d] x×y×8
Hex 1D 2A x y [d] x×y×8
Decimal 29 42 x y [d] x×y×8

[Range] $1 \leq x \leq 255$

$1 \leq y \leq 255$

$x \times y \leq 155$ (when receive buffer is 2K bytes)

$x \times y \leq 404$ (when receive buffer is 32 bytes)

[Description] Defines a downloaded bit image using the dots specified by x and y .

- x indicates the number of dots in the horizontal direction.

[Notes]

- y indicates the number of dots in the vertical direction.
- The number of dots is $x \times 8$ in the horizontal direction and $y \times 8$ in the vertical direction.
- The d indicates bit-image data.
- After a downloaded bit image is defined, it is available until another definition is made; ESC @ or ESC & is executed; the printer is reset; or the power is turned off.
- A user-defined character and a downloaded bit image cannot be defined simultaneously. When this command is executed, the user-defined character is cleared.
- The figure below shows the relationship between the bit-image data and dots to be defined.

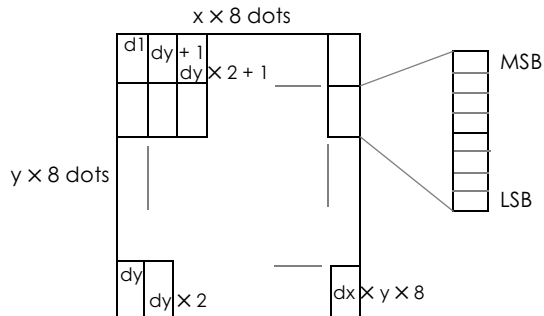

[Reference] GS/

GS/ m

[Name] Print downloaded bit image

[Format] ASCII GS / m
 Hex 1D 2F m
 Decimal 29 47 m

[Range] $0 \leq m \leq 1, 48 \leq m \leq 49$

[Description] Prints a downloaded bit image in mode m .

The modes selectable by m are as follows:

m	Print mode	Horizontal direction		Maximum number of dots	
		Dot Density	Adjacent Dot	Paper Roll	Slip
0, 48	Double-width	Single Density	Permitted	180	400
1, 49	Normal	Double Density	Prohibited	360	800

[Notes]

- Command ignored if data exists in the print buffer.
- Command ignored if no downloaded bit image has been defined.

- If a downloaded bit image to be printed exceeds one line, the excess data is not printed.
- A user-defined character and a downloaded bit image cannot be defined for the same character code.
- If the value of m is out of the specified range, the printer ignores the command.

[Reference] **GS ***

GS E n

[Name] Select print speed and head energizing time

[Format]	ASCII	GS	E	n
	Hex	1D	45	n
	Decimal	29	69	n

[Range] $0 \leq n \leq 255$

[Description] Selects the printing speed and print head energizing time (print mode), using n as follows:

Bit	Off/On	Hex	Decimal	Function
0	Off	00	0	Head energizing time (copy).
	On	01	1	Head energizing time (normal)
1-3	-	-	-	Undefined.
4	Off	00	0	High printing speed
	On	10	16	Low printing speed
5-7	-	-	-	Not used.

- [Notes]
- Command available only when input at the beginning of the line.
 - The printer processes $n = \langle \text{***}0\text{***} \rangle B$ as $n = \langle \text{***}0\text{***}1 \rangle B$.
 - The setting is for paper selected by ESC c 0.

n	Speed	Print Head	Mode	Default value	
				Paper Roll	Slip
1	High	Normal	Normal	Selectable by DIP switch	
16	Low	Copy	Copy		Default
17	Low	Normal	Low	Selectable by DIP switch	

[Default] Paper roll: $n = 1$ or 17 , depending on the DIP switch
Slip: $n = 16$

[Reference] **ESC c 0**

GS I *n*

[Name] Transmit printer ID

[Format] ASCII GS I *n*
Hex 1D 49 *n*
Decimal 29 73 *n*

[Range] $1 \leq n \leq 3, 49 \leq n \leq 51$

[Function] Transmits the printer ID specified by *n* as follows:

<i>n</i>	Printer ID	Specification	ID (hexadecimal)
1, 49	Model ID	TM-U925	0CH
2, 50	Type ID	See table below.	
3, 51	ROM version ID	ROM version	See the notes below.

n = 2, Type ID

Bit	Off/On	Hex	Decimal	Function
0	Off	00	0	Two-byte character code. Fixed to Off.
1	On	02	2	Auto-cutter enabled. Fixed to On
2	Off	00	0	DIP SW 1-6 setting OFF.
	On	04	4	DIP SW 1-6 setting ON.
3	Off	00	0	MICR function disabled.
	On	08	8	MICR function enabled.
4	Off	00	0	Not used. Fixed to Off.
5, 6	-	-	-	Undefined.
7	Off	00	0	Not used. Fixed to Off.

- [Notes]
- When DTR/DSR control is selected, the printer transmits only 1 byte after confirming that the host is ready to receive data (DSR signal is SPACE). If the host computer is not ready to receive data (DSR signal is MARK), the printer waits until the host is ready. When XON/XOFF control is selected, the printer transmits only 1 byte without confirming the condition of the DSR signal.
 - Printer ID is transmitted when data in the receive buffer is developed. Therefore, there may be a time lag between receiving this command and transmitting the status, depending on the receive buffer status.
 - The ROM version may be changed.
 - When Auto Status Back (ASB) is enabled using **GS a**, the status transmitted by **GS I** and the ASB status must be differentiated.

- When n is out of the specified range, this command is ignored.

GS P $x y$

[Name]	Set horizontal and vertical motion units			
[Format]	ASCII	GS	P	$x y$
	Hex	1D	50	$x y$
	Decimal	29	80	$x y$
[Range]	$0 \leq x \leq 255$			
	$0 \leq y \leq 255$			
[Description]	Sets the horizontal and vertical motion units to $1/x$ inch and $1/y$ inches, respectively. When x and y are set to 0, the default setting of each value is used ($x = 150$, $y = 144$).			
[Notes]	<ul style="list-style-type: none"> • This command does not affect the previously specified values. • The current settings remain unchanged after this command is executed. • The calculated result when using this command and the line spacing setting command is truncated to the minimum value of the mechanical pitch (horizontal: $1/150''$, vertical: $1/144''$) or an exact multiple of that minimum value. See the examples below. 			
[Default]	$x = 150$, $y = 144$			
[Reference]	ESC SP, ESC \$, ESC 3, ESC J, ESC K, ESC \			
[Example]	When $n=48$ in ESC 3 and GS P $x y$ is not used, the amount of paper feeding is set to $48/144$ ($1/3$ inches). When the GS P setting is $x=0$ and $y=240$ and the ESC 3 setting is $n=48$, the amount of paper feeding is set to $48/240$ (which is exactly $28/144$ inch).			
[Truncation example]	When the setting in GS P is $x=0$ and $y=240$ and in ESC 3 $n=50$, the amount of paper feeding is set to $50/240$ inch because $50/240$ is exactly $30/144$, but if the ESC 3 n setting were 54, the amount of paper feeding would also be $50/240$ ($30/144$) because $54/240$ cannot be divided into an exact number of $1/144$ -inch units. Therefore, it is truncated to 50.			

GS a n

[Name]	Enable/Disable Automatic Status Back			
[Format]	ASCII	GS	a	n
	Hex	1D	61	n
	Decimal	29	97	n
[Range]	$0 \leq n \leq 255$			

[Description] Enables or disables ASB and specifies the status items to include, using n as follows:

Bit	Off/On	Hex	Dec.	Status for ASB
0	Off	00	0	Drawer kick-out connector pin 3 status disabled.
	On	01	1	Drawer kick-out connector pin 3 status enabled.
1	Off	00	0	On-line/off-line status disabled.
	On	02	2	On-line/off-line status enabled
2	Off	00	0	Error status disabled.
	On	04	4	Error status enabled.
3	Off	00	0	Paper roll sensor status disabled.
	On	08	8	Paper roll sensor status enabled.
4	-	-	-	Undefined.
5	Off	00	0	Slip sensor and slip status disabled.
	On	20	32	Slip sensor and slip status enabled.
6.7	-	-	-	Undefined.

[Notes]

- If $n = 0$, ASB is disabled.
- ASB is enabled if only one status is selected. Printer automatically transmits a status of four bytes whenever the status changes.
- If ASB is enabled while processing this command, the current status is transmitted with no regulations.
- When transmitting a status, the printer transmits only four bytes without confirming the condition of the DSR signal.
- 4 bytes of status data must be consecutive, except for XOFF code.
- This command is executed when the data in the receive buffer is developed. Therefore, there may be a time lag between receiving this command and transmitting the status, depending on the receive buffer status.
- When the printer is disabled by **ESC =** (Select peripheral device), this command is disabled but ASB is not disabled.
- When using **ESC u**, **ESC v**, **GS I**, **GS r**, or **DLE EOT**, or **GS ENQ**, the status transmitted by this command, the ASB information, and the status transmitted by other commands must be differentiated.
- The status to be transmitted are as follows:

First byte (printer information)

Bit	Off/On	Hex	Dec.	Status for ASB
0	Off	00	0	Not used. Fixed to Off.
1	Off	00	0	Not used. Fixed to Off.
2	Off	00	0	Drawer kick-out connector pin 3 signal is LOW
	On	04	4	Drawer kick-out connector pin 3 signal is HIGH.
3	Off	00	0	On-line.
	On	08	8	Off-line.
4	On	10	16	Not used. Fixed to On.
5	Off	00	0	Cover closed.
	On	20	32	Cover open.
6	Off	00	0	Paper is not being fed by the PAPER FEED button.
	On	40	64	Paper is being fed by the PAPER FEED button.
7	Off	00	0	Not used. Fixed to Off.

Second byte (error information)

Bit	Off/On	Hex	Dec.	Status for ASB
0, 1	-	-	-	Undefined.
2	Off	00	0	No mechanical error.
	On	04	4	Mechanical error has occurred.
3	Off	00	0	No auto-cutter error.
	On	08	8	Auto-cutter error has occurred.
4	Off	00	0	Not used. Fixed to Off.
5	Off	00	0	No unrecoverable error.
	On	20	32	Unrecoverable error has occurred.
6	Off	00	0	No temporary abnormality of print head temperature.
	On	40	64	Temporary abnormality of print head temperature.
7	Off	00	0	Not used. Fixed to Off.

Third byte (paper sensor information)

Bit	Off/On	Hex	Decimal	Status for ASB
0	Off	00	0	Paper near-end sensor: paper adequate.
	On	01	1	Paper near-end sensor: paper near end.
1	Off	00	0	Paper near-end sensor: paper adequate.
	On	02	2	Paper near-end sensor: paper near end.
2	Off	00	0	Paper end sensor: paper present.
	On	04	4	Paper end sensor: no paper present.
3	Off	00	0	Paper end sensor: paper present.
	On	08	8	Paper end sensor: no paper present.
4	Off	00	0	Not used. Fixed to Off.
5	Off	00	0	Slip is detected by slip insertion sensor.
	On	20	32	Slip is not detected by slip insertion sensor.
6	Off	00	0	Slip is detected by slip ejection sensor.
	On	40	64	Slip is not detected by slip ejection sensor.
7	Off	00	0	Not used. Fixed to Off.

Fourth byte (paper sensor information)

Bit	Off/On	Hex	Decimal	Status for ASB
0	Off	00	0	Slip paper selected.
	On	01	1	Slip paper not selected.
1	Off	00	0	Slip printing possible.
	On	02	2	Slip printing not possible.
2, 3	-	-	-	Undefined.
4	Off	00	0	Not used. Fixed to Off.
5, 6	-	-	-	Undefined.
7	Off	00	0	Not used. Fixed to Off.

Bit 1: Becomes 0 (possible to print) when paper loading has finished and is 1 when slip ejection is started or when time out.
When the slip paper is selected and the printer goes to the slip waiting state:

Bits 5 and 6 of the third byte are 1 (no paper)

Bits 0 and 1 of the fourth byte are 0 (selected) and 1 (impossible to print), respectively

When the printer goes to the slip ejection waiting with slip selected:

Bits 5 and 6 of the third byte are 1 (no paper) and 0 (paper present), respectively

Bits 0 and 1 of the fourth byte are 0 (selected) and 1 (impossible to print), respectively

When printing stops due to paper-end being disabled using **ESC c 4**, bit 1 of the fourth byte (slip status) does not become 1 (impossible to print) even when there is no remaining printing space on the slip.

Use **ESC r 3** to check the remaining printing space on the slip.

[Default] $n = 0$ when DIP SW 2-5 is off, $n = 2$ when DIP SW 2-5 is on.

[Reference] **DLE EOT, ESC u, ESC v, GS ENQ, GS r**

GS r n

[Name] Transmit status

[Format] ASCII GS r n
Hex 1D 72 n
Decimal 29 114 n

[Range] $1 \leq n \leq 3, 49 \leq n \leq 51$

[Description] Transmits the status specified by n as, follows:

n	Function
1, 49	Transmits paper sensor status (same as ESC v)
2, 50	Transmits drawer kick-out connector status (same as ESC u 0)
3, 51	Transmits slip paper status

- [Notes]
- When DTR/DSR control is selected, the printer transmits only 1 byte after confirming the host is ready to receive data (DSR signal is SPACE). If the host computer is not ready to receive data (DSR signal is MARK), the printer waits until the host is ready. When XON/XOFF control is selected, the printer transmits only 1 byte without confirming the condition of the DSR signal.
 - This command is executed when the data in the receive buffer is developed. Therefore, there may be a time lag between receiving this command and transmitting the status, depending on the receive buffer status.
 - When Auto Status Back (ASB) is enabled using **GS a**, the status transmitted by **GS r** and the ASB status must be differentiated.
 - If the value of n is out of the specified range, the printer ignores this command.
 - The status types to be transmitted are shown below:

Paper sensor status ($n = 1$):

Bit	Off/On	Hex	Decimal	Status
0	Off	00	0	Paper near-end sensor: paper adequate.
	On	01	1	Paper near-end sensor: paper near end.
1	Off	00	0	Paper near-end sensor: paper adequate.
	On	02	2	Paper near-end sensor: paper near end.
2	Off	00	0	Paper end sensor: paper present.
	On	04	4	Paper end sensor: no paper.
3	Off	00	0	Paper end sensor: paper present.
	On	08	8	Paper end sensor: no paper.
4	Off	00	0	Not used. Fixed to Off.
5	Off	00	0	Slip is detected by slip insertion sensor.
	On	20	32	Slip is not detected by slip insertion sensor.
6	Off	00	0	Slip is detected by slip ejection sensor.
	On	40	64	Slip is not detected by slip ejection sensor.
7	Off	00	0	Not used. Fixed to Off.

Drawer kick-out connector status ($n = 2$):

Bit	Off/On	Hex	Decimal	Status
0	Off	00	0	Drawer kick-out connector pin 3 signal is LOW.
	On	01	1	Drawer kick-out connector pin 3 signal is HIGH.
1-3	-	-	-	Undefined
4	Off	00	0	Not used. Fixed to Off.
5, 6	-	-	-	Undefined.
7	Off	00	0	Not used. Fixed to Off.

n=3: Slip status

Value	Slip status
00000000B	There is no printing area on the current slip or slip paper is not selected.
00000001B	It is possible to print one line excluding double-height characters on the current slip.
00000010B	It is possible to print one line including double-height characters on the current slip.
00000011B	It is possible to print one line or more.

[Reference] DLE EOT, ESC u, ESC v, GS ENQ, GS a

Additional Commands for the Optional MICR Reader

DLE EOT BS *n*

[Name] Transmit real-time MICR status

[Format]	ASCII	DLE	EOT	BS	<i>n</i>
	Hex	10	04	08	<i>n</i>
	Decimal	16	4	8	<i>n</i>

[Range] $n = 1$

[Description] Transmits the selected MICR status specified by *n* in real time as follows:

<i>n</i>	Function
1	Transmits MICR status.

- [Notes]
- The status information to be transmitted is shown in the tables on the following pages.
 - The printer starts MICR status transmission when this command is buffered in the receive buffer.
 - When transmitting status, the printer transmits only 1 byte without confirming the condition of the DSR signal.
 - This command is executed even when the printer is off-line, the receive buffer is full, or in an error status.
 - The status is transmitted whenever the data sequence for **DLE EOT BS *n*** ($n = 1$) is received.

Example:

In ESC [*m nL nH* [*d*] *nL*+256 x *nH*, *d1*=<10>H, *d2*=<04>H, *d3*=<08>H, *d4* = <01>H

- This command should not be contained within another command that consists of 2 or more bytes.

Example:

If you attempt to transmit **ESC 3 n** to the printer, and then **DLE EOT BS 1** interrupts before *n* is received, the code <10>H for **DLE EOT BS 1** is processed as the code for **ESC 3 <10>H**.

- This command is unavailable when using the **ESC =** (Select Peripheral Device) to select the printer to be disabled.
- This command is ignored while the printer transmits reading results of MICR (**FS a 0**, **FS b**).
- When Automatic Status Back (ASB) is enabled using the **GS a** command, the status transmitted by the **DLE EOT BS** command and the ASB status must be differentiated.
- If the value of *n* is out of the specified range, the printer ignores this command.

n = 1: MICR status

Bit	Off/On	Hex	Decimal	Function
0	Off	00	0	Not used. Fixed to off.
1	On	02	2	Not used. Fixed to on.
2	Off	00	0	MICR function selected.
	On	04	4	MICR function not selected.
3	Off	00	0	Waiting for check paper or cleaning sheet insertion
	On	08	8	Not waiting for check paper or cleaning sheet insertion
4	On	10	16	Not used. Fixed to on.
5	Off	00	0	Check insertion sensor: paper present.
	On	20	32	Check insertion sensor: no paper.
6	Off	00	0	Check ejection sensor: paper present.
	On	40	64	Check ejection sensor: no paper.
7	Off	00	0	Not used. Fixed to off.

Bit 2:

- There may be a time lag between receiving the MICR selection command (**FS a 0**) and selecting slip paper. During this period, bit 2 remains 1 (not selected).
- Remains 0 (selected) until MICR function completes.

- Bit 3: • Becomes 0 (not waiting) just before starting MICR reading, or starting MICR head cleaning, after detecting the personal check or cleaning sheet, respectively.
- Bits 5 and 6: • Transmit the current status of the paper sensors.

[Reference] **DLE ENQ, FS a 0, FS a 1, FS a 2, FS b, FS c**

FS a 0 *n*

[Name]	Read check paper				
[Range]	$1 \leq n \leq 255$				
[Format]	ASCII	FS	a	0	<i>n</i>
	Hex	1C	61	30	<i>n</i>
	Decimal	28	97	48	<i>n</i>

[Description] Selects MICR function and reads MICR characters specified by *n* as follows:

Bit	Off/On	Hex	Decimal	Function
0	Off	00	0	Readable fonts. See table below.
	On	01	1	
1	Off	00	0	
	On	02	2	
2-7	-	-	-	Undefined

Bit 1	Bit 0	Font
Off	Off	E13B
Off	On	CMC7
On	Off	Undefined
On	On	Undefined

- [Notes]
- Command is available only when input at the beginning of a line.
 - This command is executed after being buffered in the receive buffer. Therefore, there may be a time lag between receiving this command and starting MICR reading.
 - When an undefined font is selected, this command is ignored.

- If the MICR function is not selected when this command is executed, the MICR function is selected and the printer enters the personal check waiting status. When slip paper is selected for printing, the printer ejects the current slip, and then waits for check paper to be loaded.
- When this command is executed with the MICR function selected and re-reading possible, the printer re-reads check paper.
- The personal check wait time is $t1 \times 1$ minutes (depending on the **ESC f t1 t2** setting), and the printer starts reading $t2 \times 0.1$ seconds after detecting insertion of a personal check.
- The printer processes only the real-time commands during the paper wait time.
- The check waiting status continues until: a check is inserted, the waiting state is canceled, the waiting time $t1$ set by **ESC f** elapses, or the power is turned off. When check waiting state is canceled, or when the wait time elapses, the printer ends reading abnormally. The printer starts reading when a personal check is inserted.
- When characters are not detected or when an error occurs, the printer ends reading abnormally. Otherwise, the printer ends reading normally.
- When the printer ends reading abnormally, the printer ejects paper, selects the default paper type for **ESC c 0**, and ends MICR function. When a recoverable error occurs, the printer selects the default paper type for **ESC c 0** automatically and ends MICR function when recovering from the error.
- If the characters read are not identified as the specified character font, the printer converts the data to "?".
- After ending MICR reading normally, the printer transmits header + reading status + identified character strings + NULL to the host computer. In other cases, the printer transmits header + reading status + NULL to the host computer.
- If an error occurs before transmitting the identification result, the printer does not transmit the identified result.
- When DTR/DSR control is selected, the printer transmits data consecutively after confirming whether the host computer is ready to receive data. When the host is not ready to receive data, the printer waits until the host is ready.
- When XON/XOFF control is selected, the printer transmits all data consecutively without confirming whether the host computer is ready to receive data. The data transmission must be consecutive, except for the XOFF code.
- The printer transmits all data collectively without confirming whether the host is ready to receive data.
- To receive the identification result correctly, 67 bytes or more space is required in the receive buffer.

- During identification result transmission, the printer ignores **DLE EOT n**, **DLE EOT BS n**, and **GS ENQ**. Also, the printer does not transmit ASB during reading and identification result transmission. Therefore, the user cannot confirm changes in the printer status during these periods.
- It is possible to differentiate the reading results of MICR, ASB, and real-time status.
- The identification result is not cleared until: the next **FS a 0** is executed, **ESC @** is executed, or the printer power is turned off.
- Data transmission (real-time commands and the like) should not be performed during MICR reading, because it affects the reading precision and may lower the recognition rating.
- When bit 4 is 0 (re-reading possible) and **FS a 0**, **FS a 1**, **FS a 2**, or **FS b** is received, the printer executes each command. When any other code (except for real-time commands) is received, the printer ejects the check paper, ends MICR function, and selects the default paper type for **ESC c 0** automatically.
- If the printer receives **FS a 1**, **FS a 2**, or **FS b** when bit 5 is 0 (normal end) and bit 4 is 1 (re-reading impossible), the printer executes each command. If the printer receives any other code (except for real-time commands), the printer ejects the check, ends MICR function, and selects the default paper type for **ESC c 0** automatically.
- Paper feeding with the paper feed button and auto loading cannot be performed during the period from starting MICR character reading to ending check paper ejection. Also, do not change the ink ribbon during this period.

Header: <5F>H

NUL: <00>H

Each bit of n is used as follows:

Bit	Off/On	Hex	Decimal	Function
0	Off	00	0	Readable fonts. See the table below.
	On	01	1	
1	Off	00	0	
	On	02	2	
2, 3	-	-	-	Undefined.
4	Off	00	0	Rereading possible
	On	10	16	Rereading not possible.

Bit	Off/On	Hex	Decimal	Function
5	Off	00	0	Reading result: normal end.
	On	20	32	Reading result: abnormal end
6	On	40	64	Not used. Fixed to on.
7	Off	00	0	Not used. Fixed to off.

Bit 1	Bit 0	Font
Off	Off	E13B
Off	On	CMC7
On	Off	Undefined
On	On	Undefined

- Bits 0 and 1:
- Identified character fonts. When bit 5 is 1 (abnormal end), neither bit 0 nor bit 1 has any meaning.
 - The identified characters consist of the following:

E13B

CMC7

[Reference] **DLE EOT BS, DLE ENQ, ESC f, FS b**

FS a 1

[Name] Load check paper to print starting position

[Format]	ASCII	FS	a	1
	Hex	1C	61	31
	Decimal	28	97	49

[Description] Loads check paper to the print starting position.

[Notes]

- Since this command is executed after being buffered in the receive buffer, there may be a time lag between receiving this command and starting MICR reading.
- This command is ignored unless MICR function is selected.
- After loading check paper to the print starting position, the printer cancels the MICR function and selects slip paper automatically.

[Reference] **FS a 0**

FS a 2

[Name] Eject check paper

[Format]	ASCII	FS	a	2
	Hex	1C	61	32
	Decimal	28	97	50

[Description] Ejects check paper.

- [Notes]
- Since this command is executed after being buffered in the receive buffer, there may be a time lag between command reception and starting paper ejection.
 - This command is ignored unless the MICR function is selected.
 - After ejecting check paper, the printer cancels the MICR function and selects the default paper for **ESC c 0** automatically.

[Reference] **ESC c 0, FS a 0**

FS b

[Name] Request retransmission of check paper reading result

[Format]	ASCII	FS	b
	Hex	1C	62
	Decimal	28	98

[Description] Retransmits the previous check paper (MICR character) reading results.

- [Notes]
- This command is executed after being buffered in the receive buffer. Therefore, there may be a time lag between sending this command and starting MICR reading.
 - When the previous MICR reading results are correct, the printer transmits header + reading status + identified character strings + NULL to the host computer. If it is abnormal, or when **FS a 0** is not executed, the printer transmits header + reading status + NULL to the host.
 - When DTR/DSR control is selected, the printer transmits data consecutively after confirming whether the host computer is ready to receive data. When the host is not ready to receive data, the printer waits until the host is ready.
 - When XON/XOFF control is selected, the printer transmits all data consecutively without confirming whether the host computer is ready to receive data. The data transmission must be consecutive, except for the XOFF code.
 - The printer transmits all data collectively without confirming whether the host computer is ready to receive data after transmitting header. To receive the identification result correctly, 67 bytes or more space is required in the receive buffer.
 - See the **FS a 0** command description for header, reading status, and identified character strings.

- During identification result transmission, the printer ignores **DLE EOT *n***, **DLE EOT BS *n***, and **GS ENQ**. Also, the printer does not transmit ASB during reading and identification result transmission. Therefore, the user cannot confirm changes in the printer status during these periods.
- It is possible to differentiate the reading results of MICR, ASB, and real-time status.

[Reference] **DLE EOT BS, DLE EOT, FS a 0, GS ENQ**

FS c

[Name] MICR mechanism cleaning

[Format]	ASCII	FS	c
	Hex	1C	63
	Decimal	28	99

[Description] Cleans the MICR mechanism.

- [Notes]
- Command is available only when input at the beginning of a line.
 - This command is executed after being buffered in the receive buffer. Therefore, there may be a time lag between sending this command and starting head cleaning.
 - When this command is executed, the printer enters the cleaning sheet wait status.
 - When this command is executed with slip paper selected, the printer ejects the slip paper and waits for the cleaning sheet to be loaded.
 - The cleaning sheet waiting time is $t1 \times 1$ minutes, based on the **ESC f *t1 t2*** setting. The printer starts operation $t2 \times 0.1$ seconds after detecting a cleaning sheet.
 - The printer waits for the cleaning sheet until a cleaning sheet is inserted, the cleaning sheet waiting status is canceled, the waiting time is over, or the power is turned off.
 - During the cleaning sheet waiting period, the printer processes only real-time commands.
 - The printer starts MICR mechanism cleaning when the cleaning sheet is loaded.
 - After cleaning the MICR mechanism, the printer ejects the sheet and automatically selects the default paper type for **ESC c 0**.

[Reference] **ESC c 0, ESC f**

Ignored Commands

The TM-U925 ignores the following commands:

ESC c 3 *n*

ESC c 6 *n*

Printed in Japan

1999.12